



Oxford Cambridge and RSA

Wednesday 24 May 2023 – Afternoon

A Level Physics B (Advancing Physics)

H557/01 Fundamentals of Physics

Time allowed: 2 hours 15 minutes



You must have:

- the Data, Formulae and Relationships Booklet

You can use:

- a scientific or graphical calculator
- a ruler (cm/mm)



Please write clearly in black ink. **Do not write in the barcodes.**

Centre number

--	--	--	--	--

Candidate number

--	--	--	--

First name(s)

Last name

INSTRUCTIONS

- Use black ink. You can use an HB pencil, but only for graphs and diagrams.
- Write your answer to each question in the space provided. If you need extra space use the lined pages at the end of this booklet. The question numbers must be clearly shown.
- Answer **all** the questions.
- Where appropriate, your answer should be supported with working. Marks might be given for using a correct method, even if your answer is wrong.

INFORMATION

- The total mark for this paper is **110**.
- The marks for each question are shown in brackets [].
- Quality of extended response will be assessed in questions marked with an asterisk (*).
- This document has **40** pages.

ADVICE

- Read each question carefully before you start your answer.

2
Section A

You should spend a **maximum of 40 minutes** on this section.

Write your answer for each question in the box provided.

- 1 The diagram shows a dot-plot of measurements of diameter at points along a wire.

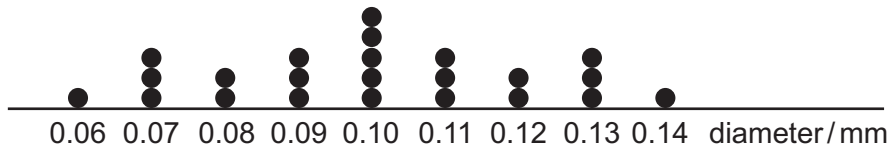

Which of the following statements is correct?

- A A value of 0.17 mm would be an outlier.
- B The percentage uncertainty in the value is 4%.
- C The range of the results is 0.08 mm.
- D The spread of the results is ± 0.14 mm.

Your answer

[1]

- 2 Two scalar quantities are:

- A distance and acceleration
- B mass and potential energy
- C velocity and momentum
- D work done and force

Your answer

[1]

3

3 A mass of 0.5 kg of water at 25 °C is placed in a microwave oven and heated for 30 s.

The final temperature of the water is 30 °C. What is the rate of energy transfer to the water?

specific thermal capacity of water = 4200 J kg⁻¹ K⁻¹

- A 350 W
- B 700 W
- C 2100 W
- D 10 500 W

Your answer

[1]

4 An asteroid travelling at a constant velocity is observed. A radar pulse emitted at time $t = 0.00$ s reflects from the asteroid and is detected at time $t = 6.00$ seconds.

Ten minutes after the first pulse, a second pulse is emitted. This pulse returns after 5.98 seconds.

What is the component of velocity of the asteroid in the direction of the Earth?

- A 5.0 km s⁻¹
- B 10 km s⁻¹
- C 300 km s⁻¹
- D 600 km s⁻¹

Your answer

[1]

5 Which of the following statements about the Universe is correct?

- A Hubble's Law shows that our galaxy is at the centre of the Universe.
- B The age of a galaxy can be calculated by Hubble's Law.
- C The cosmic microwave background radiation is produced by decaying nuclei in distant galaxies.
- D The cosmological redshift is produced by light travelling through expanding space.

Your answer

[1]

6 Two parallel conducting plates **P** and **Q** have a p.d. V between them. They are separated by distance d .

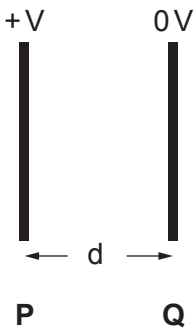

Which graph shows the variation of electric field strength E with distance x from plate **P**?

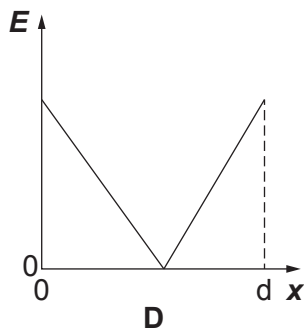
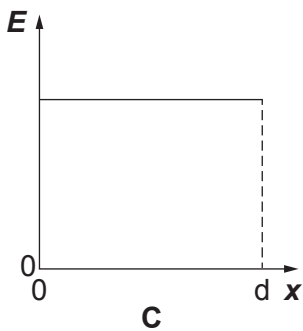
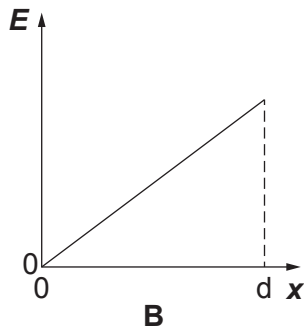
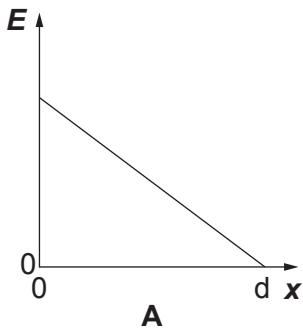

Your answer

[1]

7 Here are some data for an ideal transformer:

number of turns on primary coil = 200

number of turns on secondary coil = 400

primary voltage = 18.0V

output power = 12.0W

What is the best estimate of the current in the secondary coil?

A 0.33A

B 0.67A

C 3.0A

D 9.0A

Your answer

[1]

8 Which value is the best estimate of the ratio $\frac{\text{nuclear diameter}}{\text{atomic diameter}}$

A 10^{-2}

B 10^{-5}

C 10^{-8}

D 10^{-11}

Your answer

[1]

- 9 A nucleus decays by alpha emission. The nucleus formed then decays by beta emission. Which graph of nucleon number N plotted against proton number Z shows the two decays?

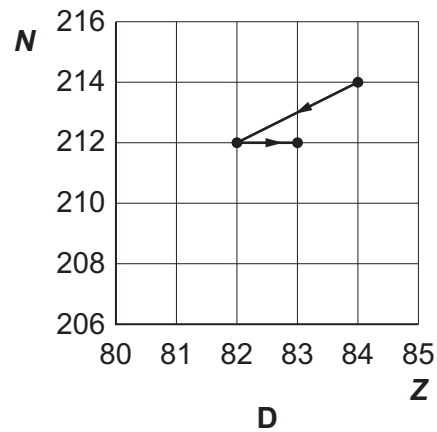
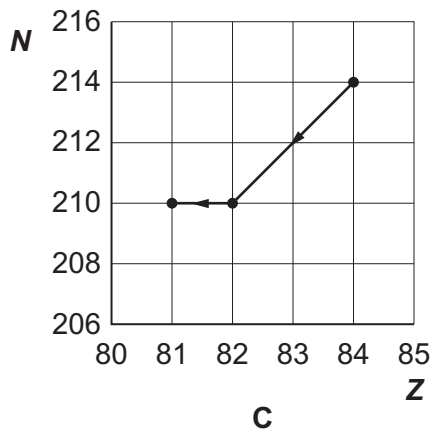
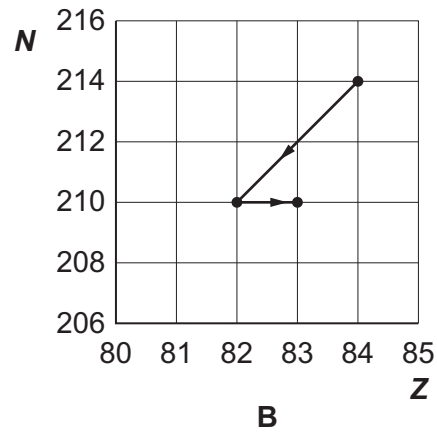
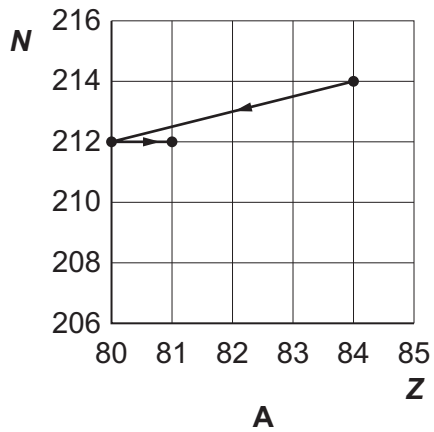

Your answer

[1]

- 10 The unit of capacitance is the farad F.

1 F is the same as:

- A $1 \text{As}\Omega^{-1}$
 B 1VA^{-1}
 C 1VC^{-1}
 D $1 \Omega^{-1} \text{s}$

Your answer

[1]

11 A signal is recorded.

The total amplitude of the signal voltage varies from zero to 2.56 mV.

The noise in the signal is 2.5×10^{-3} mV.

The highest frequency component of the signal is 8000 Hz.

Which of the following statements is correct?

- A 1025 bits per sample is the maximum useful number before redundant information is stored.
- B Increasing the rate of sampling will improve the resolution of the amplitude of the signal.
- C The minimum rate of sampling required for an accurate result is 1.6×10^5 bit s⁻¹.
- D The sampling frequency should not be more than 4000 Hz.

Your answer

[1]

12 Which one of the following statements about materials is correct?

- A Alloys are tougher than pure metals because small numbers of alloying atoms resist the movement of dislocations.
- B Ceramics are more brittle than pure metals because there is no movement of free electrons within the material.
- C Ductile materials can show elastic deformation.
- D Polymers can show large elastic strains because the long chain molecules slip over one another.

Your answer

[1]

- 13 A pencil of length 0.15 m is placed 1.20 m from a lens of power +5.00 D and forms a clear image.

What is the length of the image of the pencil?

- A 0.02 m
- B 0.03 m
- C 0.14 m
- D 0.20 m

Your answer

[1]

- 14 Two wires **X** and **Y** are compared.

Wire **X** has resistivity ρ , length L and cross-sectional area A .

Wire **Y** has resistivity $\rho/2$, length $L/2$ and cross-sectional area $A/4$.

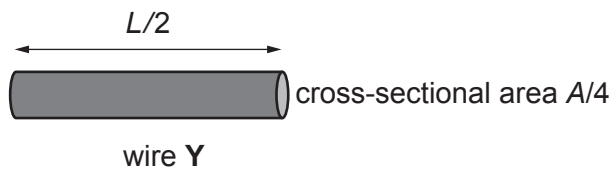
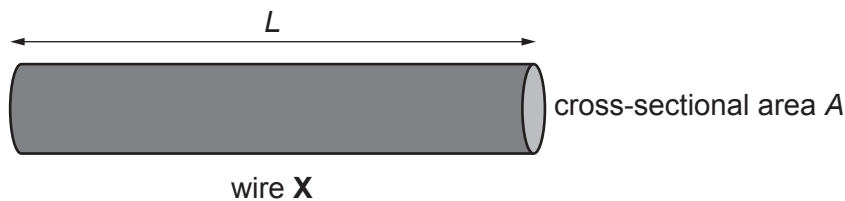

The resistance of wire **X** is $3.0\ \Omega$.

What is the resistance of wire **Y**?

- A $1.5\ \Omega$
- B $3.0\ \Omega$
- C $4.5\ \Omega$
- D $6.0\ \Omega$

Your answer

[1]

15 Red light of wavelength 670 nm is incident at right angles on a diffraction grating.

A first order maximum is produced at 10° .

Light of a different colour produces a second order maximum at 12° .

What is the wavelength of the second light source?

A 280 nm

B 400 nm

C 560 nm

D 780 nm

Your answer

[1]

16 A 2.0 kg mass is pulled up a slope of length 9.0 m at constant speed. The slope is at an angle of 20° to the horizontal. A constant frictional force of 20 N acts down the slope.

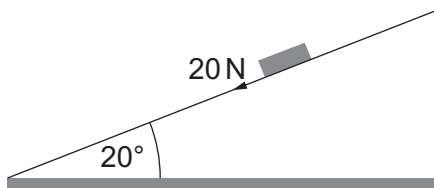

How much work is done pulling the mass up the full length of the slope?

A 180 J

B 240 J

C 346 J

D 974 J

Your answer

[1]

17 A cable supports a lift of mass 900 kg.

At $t = 0$ s the lift is stationary. At $t = 0.5$ s the lift starts accelerating upwards at 2.0 ms^{-2} until $t = 1.5$ s when it maintains a constant vertical velocity for a further 2.0 s.

How does the tension in the cable change in this time?

A

Time/s	0.0	1.0	2.0	3.0
Tension/N	0	1800	1800	1800

B

Time/s	0.0	1.0	2.0	3.0
Tension/N	8820	10620	10620	10620

C

Time/s	0.0	1.0	2.0	3.0
Tension/N	8820	10620	8820	8820

D

Time/s	0.0	1.0	2.0	3.0
Tension/N	10620	10620	10620	1800

Your answer

[1]

18 An egg is dropped from a height of 2.5 m.

It lands on a soft surface and is reduced to zero velocity in 0.25 s.

What is the impulse exerted on the egg by the decelerating force?

Mass of egg = 0.080 kg

A 0.56 Ns

B 2.2 Ns

C 3.9 Ns

D 7.0 Ns

Your answer

[1]

19 The diagram shows some of the energy levels of a hydrogen atom.

$$n = 4 \quad \text{—————} \quad E_4 = -0.85 \text{ eV}$$

$$n = 3 \quad \text{—————} \quad E_3 = -1.51 \text{ eV}$$

$$n = 2 \quad \text{—————} \quad E_2 = -3.40 \text{ eV}$$

$$n = 1 \quad \text{—————} \quad E_1 = -13.6 \text{ eV}$$

An electron with kinetic energy 12.5 eV makes an inelastic collision with a hydrogen atom in its lowest energy ($n=1$) state. The electron in the atom moves to a higher energy level.

How many different frequencies of photon can be emitted by the atomic electron as it returns to the E_1 energy level?

- A 2
- B 3
- C 4
- D 5

Your answer

[1]

20 A closed cylinder contains equal numbers of particles of two ideal gases, **X** and **Y**.

Particles of gas **X** have twice the mass of particles of gas **Y**.

Which is the correct statement?

- A Both gases make the same number of collisions with the walls of the cylinder each second.
- B Gas **Y** particles have the same average kinetic energy as gas **X** particles.
- C Gas **Y** particles have twice the r.m.s. speed of gas **X** particles.
- D The particles of gas **X** exert twice the pressure on the walls of the cylinder as the particles of gas **Y**.

Your answer

[1]

- 21 Pions are particles with a half-life of 1.8×10^{-8} s when they are not moving relative to an observer.

Accelerated pions are observed to have a half-life of 3.1×10^{-8} s.

What is the relative speed of these pions?

- A $3.0 \times 10^7 \text{ m s}^{-1}$
 B $1.7 \times 10^8 \text{ m s}^{-1}$
 C $2.4 \times 10^8 \text{ m s}^{-1}$
 D $2.9 \times 10^8 \text{ m s}^{-1}$

Your answer

[1]

- 22 A d.c. power supply is connected to a resistor combination as shown. The ammeter reads 2.0 A. The p.d. across the 3.0Ω resistor is 6.0 V.

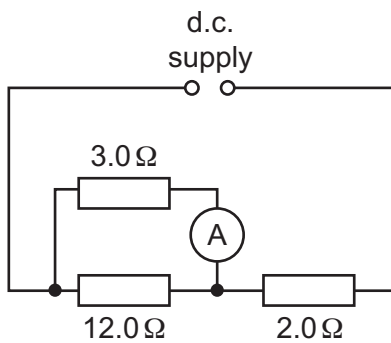

What is the e.m.f. of the d.c. power supply?

Ignore the internal resistance of the power supply.

- A 6.0 V
 B 10.0 V
 C 11.0 V
 D 12.0 V

Your answer

[1]

23 A $220\ \mu\text{F}$ capacitor discharges through a resistor R .

The p.d. across the capacitor falls to 20% of its original value after 5 seconds.

What is the value of resistor R ?

- A $14\ \Omega$
- B $32\ \Omega$
- C $14\ \text{k}\Omega$
- D $32\ \text{k}\Omega$

Your answer

[1]

24 A $4700\ \mu\text{F}$ capacitor is connected across a $6.0\ \text{V}$ supply as shown. It is discharged through a $6.0\ \text{k}\Omega$ resistor.

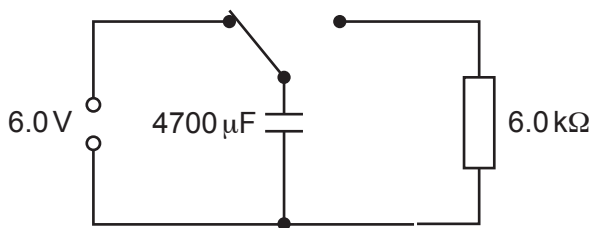

How long does it take, after the discharge starts, for the energy E stored on the capacitor to fall to half its original value, $\frac{E}{2}$?

- A 7.1 s
- B 9.8 s
- C 14.1 s
- D 19.5 s

Your answer

[1]

- 25 Io is a natural satellite of Jupiter. A pendulum is calculated to have a period of 3.50 s on the Moon and 3.30 s on Io.

What is the ratio $\frac{\text{gravitational field strength on the surface of Io}}{\text{gravitational field strength on the surface of the Moon}}$?

- A 0.89
- B 0.94
- C 1.06
- D 1.12

Your answer

[1]

- 26 A hawk glides in a horizontal circle of radius 12 m.

The speed of the hawk is 8.9 m s^{-1} .

What is the ratio $\frac{\text{weight of hawk}}{\text{centripetal force on hawk}}$?

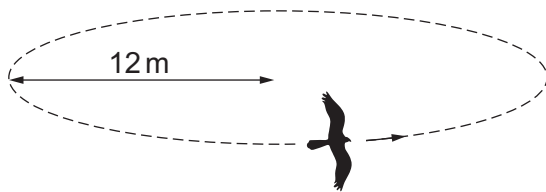

- A 1.0
- B 1.5
- C 2.0
- D 2.5

Your answer

[1]

The following information is for use in questions 27 and 28.

The radioisotope ^{222}Ra has decay constant of $5.35 \times 10^{-7} \text{ s}^{-1}$.

The radioisotope ^{222}Ac has decay constant of $8.0 \times 10^{-7} \text{ s}^{-1}$.

Samples of the two isotopes are prepared which have the same initial activity.

27 The ^{222}Ra sample has 1.0×10^{-14} mol of nuclei.

How many mol of nuclei are in the ^{222}Ac sample?

A 3.3×10^{-15} mol

B 5.0×10^{-15} mol

C 6.7×10^{-15} mol

D 1.5×10^{-14} mol

Your answer

[1]

28 After t seconds, the activity of the ^{222}Ac is 40% of its original value.

What is the activity of the ^{222}Ra at t seconds, compared to its original value?

A 46%

B 50%

C 54%

D 58%

Your answer

[1]

- 29 An electron is at a distance of 2.0×10^{-10} m from a proton. Point X is separated from each particle by 1.0×10^{-10} m.

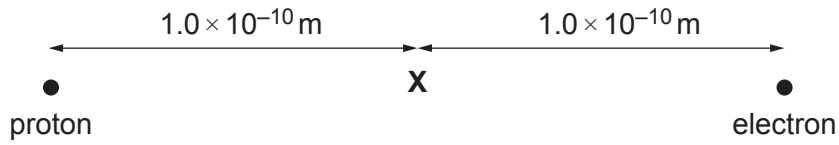

What is the electrostatic potential at point X?

- A 0.0 V
- B 2.3×10^{-8} V
- C 4.6×10^{-8} V
- D 2.9×10^{11} V

Your answer

[1]

- 30 An electron travelling at 8.5×10^6 m s⁻¹ enters a uniform magnetic field of flux density 0.57 mT.

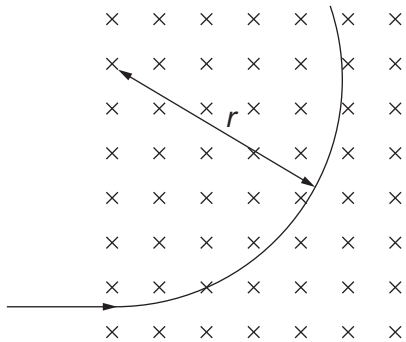

What is the radius r of the circular path of the electron in the field?

- A 8.5 mm
- B 4.3 cm
- C 8.5 cm
- D 11.8 m

Your answer

[1]

Section B

31 (a) Electromagnetic waves can be polarised.

State the difference between a polarised and an unpolarised wave.

.....
..... [1]

(b) It is suggested that visible light is partially polarised when it is reflected.

Describe how you can use a polarising filter to determine if this suggestion is correct.

.....
.....
.....
..... [2]

32 A webcam is used to stream a lesson to students at home.

(a) The webcam has a sensor of 1280×720 pixels. Each pixel uses 24 bits to code light intensity.

(i) Calculate the number of bits in a single image uploaded from the webcam.

number = bits [1]

(ii) The number of bits per image is reduced by a process called compression.

The camera captures 30 images each second. A recording of a 40-minute lesson is uploaded from the webcam to a computer and stored. The stored file uses 0.74 Gbytes of memory.

Show that this suggests an average file size of about 82 kbits for each image.

[1]

(b) A second camera has a greater number of pixels. The teacher decides **not** to use this camera for streaming lessons.

Suggest **two** reasons for this decision.

1

.....

2

.....

[2]

33 An electron is accelerated from rest through a potential difference of 5000 V.

(a) Calculate the velocity of the accelerated electron, ignoring relativistic effects.

electron mass = 9.1×10^{-31} kg

velocity = ms^{-1} [2]

(b) A much greater potential difference is used to accelerate electrons which reach a relativistic factor γ of 1.7.

Calculate the accelerating potential difference.

rest energy of electron = 8.2×10^{-14} J

potential difference = V [2]

(c) Suggest why particles are accelerated to very high energies in nuclear scattering experiments.

.....

..... [1]

- 34 The graph shows how the current I through a lamp filament varies with the potential difference across the filament.

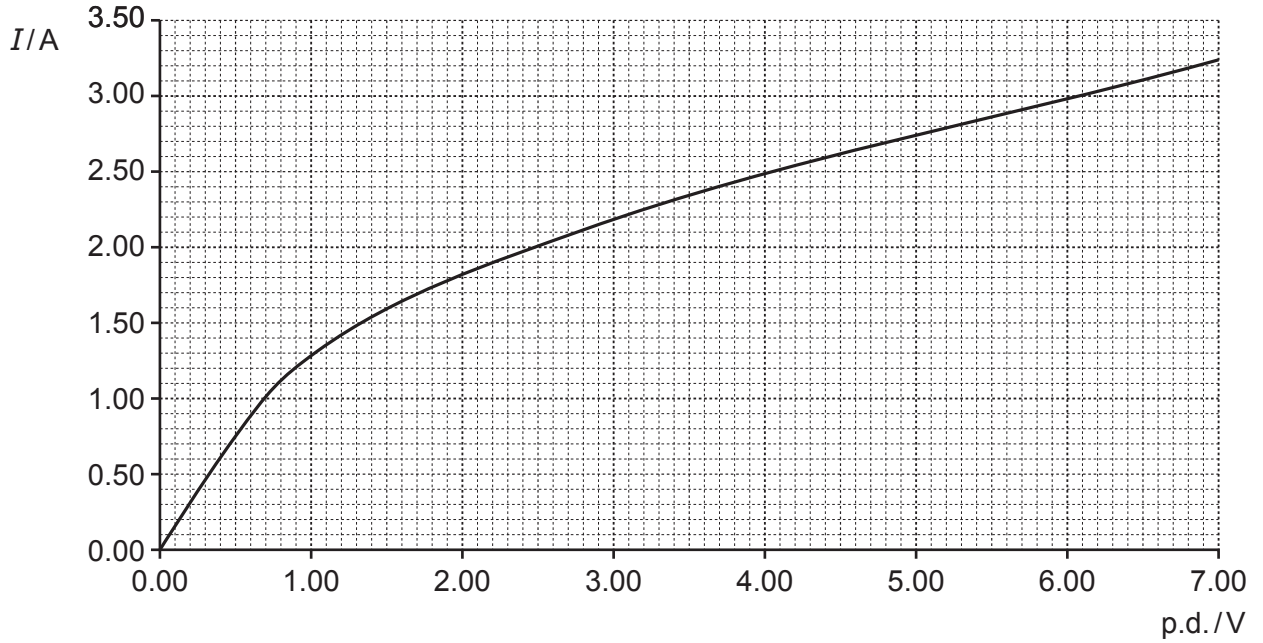

- (a) Show that the resistance of the filament when carrying 2.5A is 1.6Ω .

[1]

- (b) The conductivity of the filament at a resistance of 0.93Ω is $1.8 \times 10^7 \text{ S m}^{-1}$.

Calculate the conductivity of the filament when carrying a current of 2.5A.

conductivity = S m^{-1} [2]

- (c) Suggest and explain why the conductivity changes as the current through the filament increases.

.....

.....

.....

..... [2]

35 The diagram shows the path of an alpha particle as it passes close to a gold nucleus.

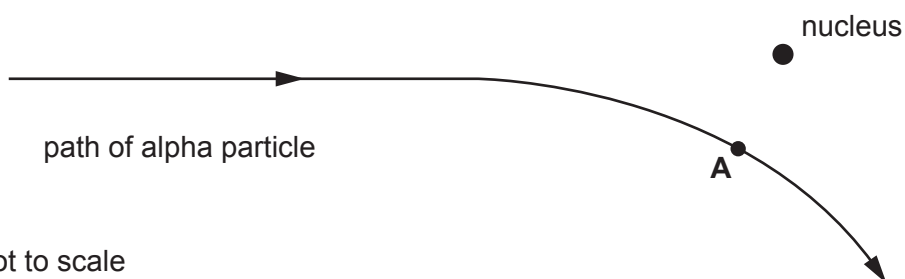

Not to scale

(a) The kinetic energy of the particle when it is far from the nucleus is $8.0 \times 10^{-13} \text{ J}$.

At point **A**, the point of closest approach to the nucleus, the kinetic energy of the particle is $4.0 \times 10^{-13} \text{ J}$.

Calculate the distance to the nucleus when the particle is at **A**.

Charge on an alpha particle = $3.2 \times 10^{-19} \text{ C}$

Charge on a gold nucleus = $1.3 \times 10^{-17} \text{ C}$

distance = m [2]

(b) Explain why the acceleration of the alpha particle is greatest at position **A**.

.....

.....

.....

..... [2]

Section C

36 This question is about the gravitational field between the Earth and the Moon.

(a) Show that the gravitational **potential** at the surface of the Moon is about $-2.9 \times 10^6 \text{ J kg}^{-1}$.

Ignore the effects of other masses in the Solar System.

$$\text{mass of moon} = 7.3 \times 10^{22} \text{ kg}$$

$$\text{radius of moon} = 1.7 \times 10^6 \text{ m}$$

[1]

(b) (i) Show that the initial velocity needed for a projectile to leave the surface of the Moon and reach an infinite distance away is about $2.4 \times 10^3 \text{ m s}^{-1}$.

Ignore the effects of other masses in the Solar System.

[2]

- (ii) Explain why the initial velocity needed for a projectile to be sent from the Moon's surface to the Earth as shown in **Fig. 36.1** is less than the value given in **b(i)**.

Fig. 36.1

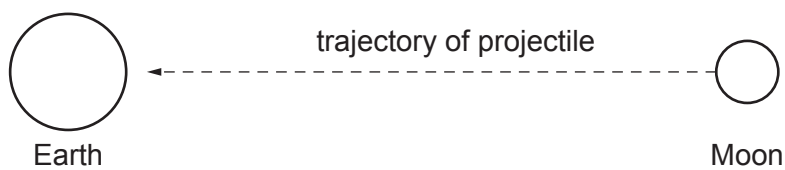

Not to scale

.....

.....

.....

.....

..... [2]

(c)* It is suggested that projectiles can be launched from the Moon to the Earth by spinning an arm at great speed. The projectile is attached to the end of the arm and released when at the necessary speed of 1900 m s^{-1} . Fig. 36.2 represents this system. The length of the arm is 20 m.

Fig. 36.2

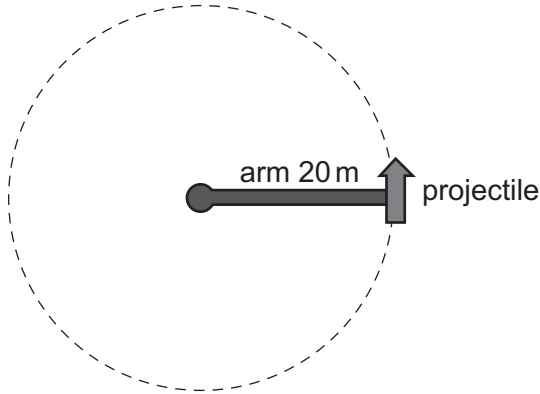

Calculate the number of rotations per second when the speed of the projectile is 1900 m s^{-1} .

Suggest and explain **two** changes to the system that would reduce the stress on the cross-section of the arm when the speed of the projectile is 1900 m s^{-1} .

Explain which change you think is the better method of reducing the stress on the arm.

The mass of the projectile cannot be changed.

.....

.....

.....

.....

.....

.....

.....

.....

.....

.....

.....

.....

.....

.....

.....

.....

.....

.....

.....

.....

.....

.....

.....

.....
..... [6]

Additional answer space if required:

.....
.....
.....
.....
.....

37 A student constructs a light sensor circuit as shown in Fig. 37.1.

Fig. 37.1

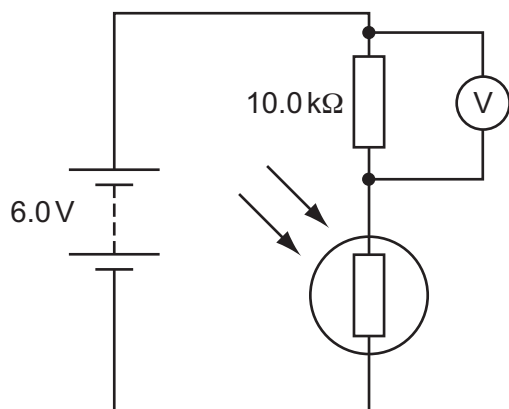

The student records the p.d. across the fixed resistor as the brightness of the light incident on the LDR is measured with a lux meter. This measure of brightness is called illuminance. A graph of the data is shown in Fig. 37.2.

Fig. 37.2

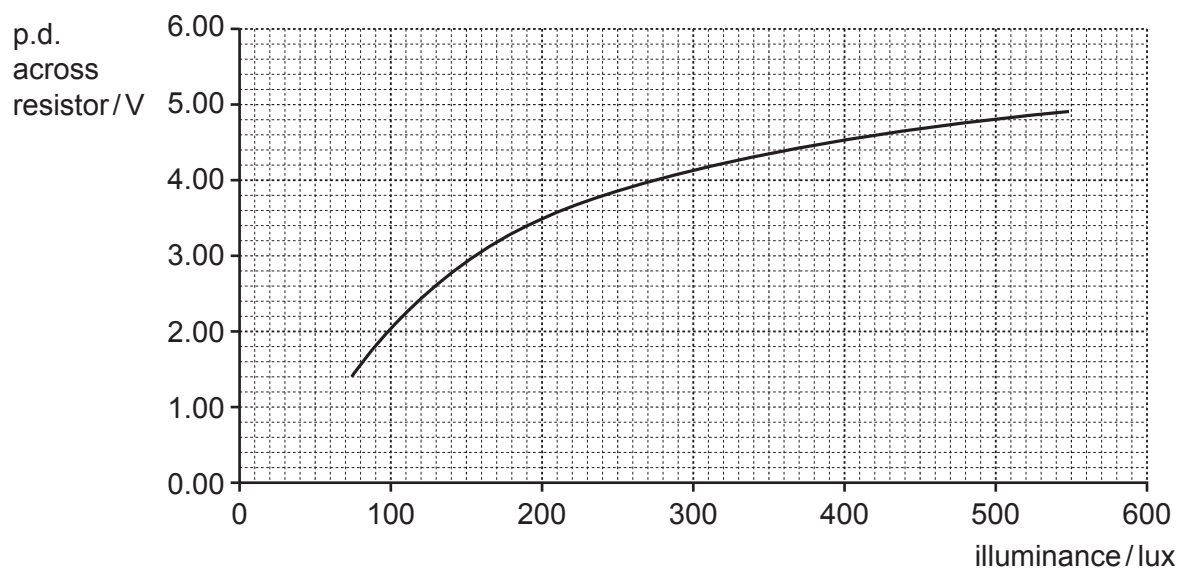

- (a) (i) Use data from the circuit diagram and the graph to show that the resistance of the LDR is about $7 \text{ k}\Omega$ when the illuminance of the light is 200 lux .

[2]

- (ii) Use **Fig. 37.2** to determine the sensitivity of the sensor at an illuminance of 200 lux.

sensitivity = V/lux [2]

- (iii) The student places transparent sheets between the light source and the lux meter. The graph in **Fig. 37.3** shows how the illuminance detected varies with the number of sheets.

Fig. 37.3

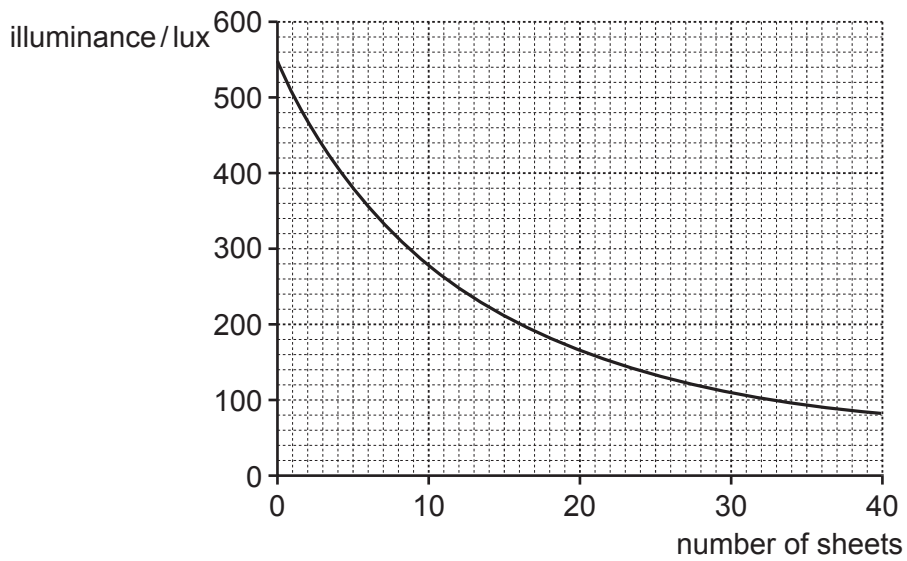

Use data from **Fig. 37.3** to test the suggestion that the illuminance falls exponentially as the number of sheets increases.

[3]

- (b) As gamma rays pass through a dense material such as lead, the intensity of the beam I varies exponentially as described by the equation $I = I_0 e^{-\mu x}$ where I_0 is the original intensity, x the thickness of the absorbing material and μ is a constant called the absorption coefficient.

Fig. 37.4 represents the apparatus used to determine the absorption coefficient of lead.

Fig. 37.4

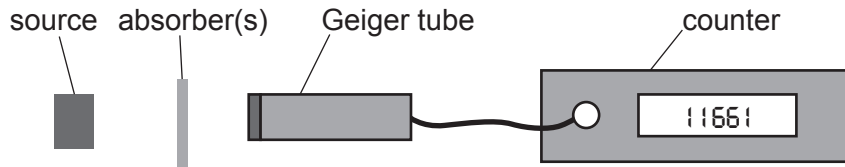

- (i) Describe how this apparatus can be used to gather data to determine the absorption coefficient of the absorbing material.

.....

.....

.....

.....

.....

..... [3]

- (ii) The intensity of a gamma-ray beam is reduced to 15% of its original value after passing through 3.2 cm of lead.

Calculate the absorption coefficient of the lead.

absorption coefficient = cm^{-1} [2]

29
BLANK PAGE

PLEASE DO NOT WRITE ON THIS PAGE
Section C continues on page 30

.....

.....

.....

.....

.....

.....

(b) Here are some data about a steel wire:

original length: 1.4 m

cross-sectional area: $0.52 \times 10^{-6} \text{m}^2$

Young Modulus: $2.8 \times 10^{11} \text{Pa}$

yield stress = $3.5 \times 10^8 \text{N m}^{-2}$

(i) Calculate the extension at which the wire will begin to show plastic deformation.

extension = m **[2]**

(ii) Calculate the energy stored in the wire at the extension calculated in **(b)(i)**.

energy stored = J **[2]**

- (iii) The wire is replaced with one of twice the length of the original wire. The new wire is of the same material and cross-sectional area as the original wire.

State how this change will affect the yield strain and energy stored at yielding point.

.....
..... [2]

- (iv) Floating oil rigs are towed into position by small, powerful boats called tugs.

Suggest and explain why long cables are used to attach the rig to the tugs.

.....
.....
.....
..... [2]

- 39 Before the discovery of nuclear fusion, one explanation for the Sun's energy output was that the Sun gradually shrinks and its gravitational potential energy is transferred to other forms.

The theory stated that a star can provide energy through gravitational contraction for a time τ given by:

$\tau = \frac{GM^2}{RL}$ where R is the original radius of the star, L is the average energy output, M is the mass of the star and G the universal constant of gravitation.

- (a) Estimate the lifetime of the Sun if gravitational contraction is the source of its energy. State your answer in years.

$$M = 2.0 \times 10^{30} \text{ kg}$$

$$R = 7.0 \times 10^8 \text{ m}$$

$$L = 3.9 \times 10^{26} \text{ J s}^{-1}$$

lifetime of Sun = years [2]

- (b) It is now recognised that the source of the Sun's energy is fusion reactions taking place in the core. This is a three-stage process. The first stage is represented by the equation below:

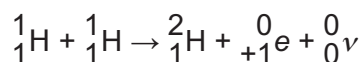

- (i) Complete the table below:

	Before reaction	After reaction
Total number of up quarks		
Total number of down quarks		

[1]

- (ii) Explain how the equation shows that lepton number is conserved in the reaction.

.....

 [1]

(c) The second and third stages of the process are:

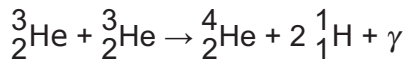
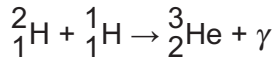

The graph in **Fig. 39.1** shows the average binding energy **per nucleon** of each of the nuclei involved in the fusion process.

Fig. 39.1

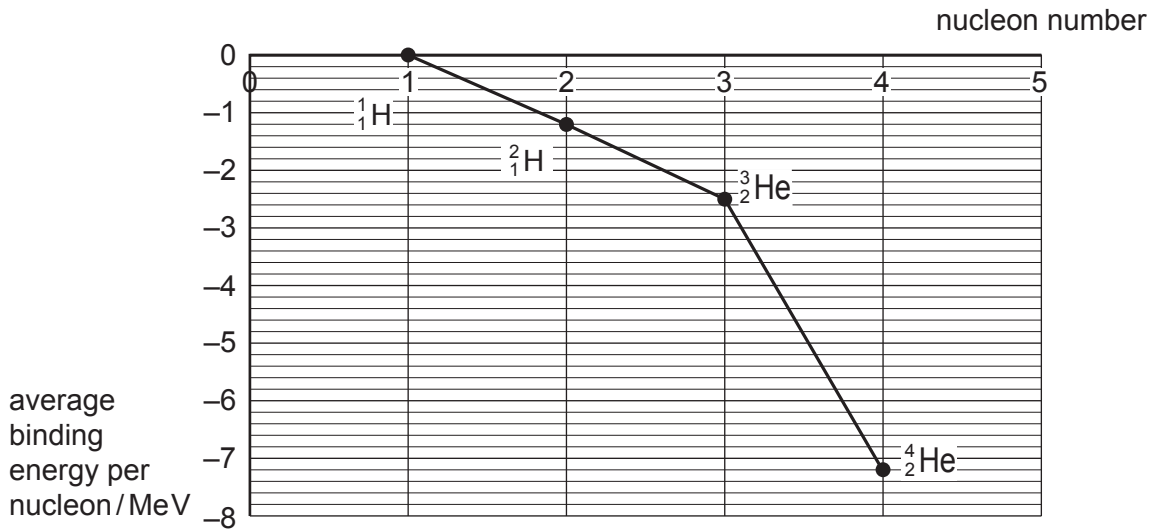

(i) Use data from **Fig. 39.1** to show that the total energy released in the three-stage process is about 5×10^{-12} J.

[2]

(ii) Use the value for the average energy output, L , of the Sun to calculate the number of fusion reactions per second.

$$L = 3.9 \times 10^{26} \text{ J s}^{-1}$$

number = [2]

(iii) Calculate the rate at which mass is being converted to energy in the Sun.

rate = kg s^{-1} [2]

(iv) The age of the Earth is about 4.5 billion years.

Use your answer to (c)(iii) to calculate the percentage of the solar mass converted to energy in 4.5 billion years.

Explain why the age of the Earth shows that fusion is a better explanation for the source of the Sun's energy than gravitational contraction.

Mass of Sun = $2.0 \times 10^{30} \text{ kg}$

percentage of solar mass converted to energy = %

.....
.....
.....
..... [3]

40 Fig. 40.1 shows how the potential energy of a mass-on-a-spring oscillator varies with distance from the equilibrium point (zero displacement) to the amplitude A.

Fig. 40.1

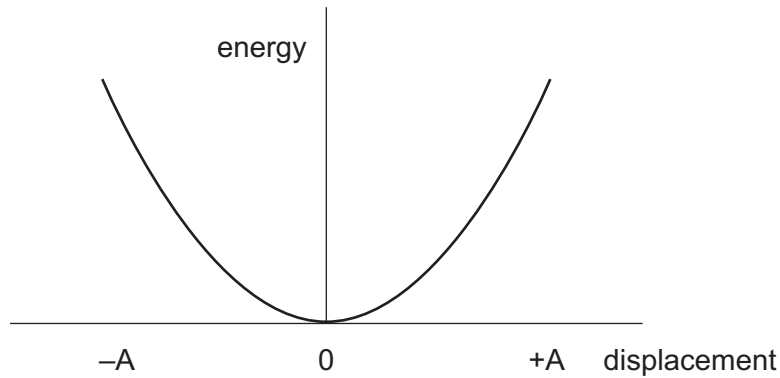

(a) Draw a curve on Fig. 40.1 showing the kinetic energy of the oscillator.

Label this curve 'kinetic energy'.

[1]

(b) A mass oscillates between two springs as shown in Fig. 40.2.

Fig. 40.2

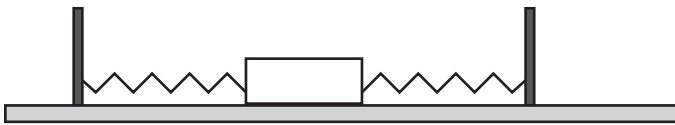

It is released from its maximum displacement of 0.050 m at $t = 0.0$ s. The frequency of the oscillation is 0.80 Hz.

The velocity v of a simple harmonic oscillator is given by the equation:

$$v = \pm 2\pi f \sqrt{A^2 - x^2}$$

where A is the amplitude of oscillation and x the displacement.

Calculate the velocity of the oscillator at $t = 0.25$ s.

velocity = ms^{-1} [3]

- (c) The hydrogen chloride molecule can be modelled as a mass-on-a-spring oscillator. The chlorine ion remains stationary as the much less massive hydrogen ion oscillates (**Fig. 40.3**).

Fig. 40.3

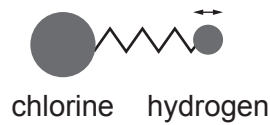

(not to scale)

The spring constant k of the system is 520 N m^{-1} . The mass of the hydrogen ion is $1.7 \times 10^{-27} \text{ kg}$.

- (i) Calculate the frequency of the oscillation of the molecule.

$f = \dots\dots\dots \text{ Hz [2]}$

- (ii) The hydrogen chloride molecule only absorbs and emits photons of specific frequencies.

Suggest and explain what this shows about the possible amplitudes of oscillation of the molecule.

.....
.....
.....
.....
.....
.....
.....
..... [3]

END OF QUESTION PAPER

ADDITIONAL ANSWER SPACE

If additional space is required, you should use the following lined page(s). The question number(s) must be clearly shown in the margin(s).

This section of the page is a large, empty area for writing answers. It consists of a vertical solid line on the left side, creating a margin, and a series of horizontal dotted lines extending across the page to the right. The dotted lines are spaced evenly, providing a guide for writing.

A set of horizontal dotted lines for writing, spanning the width of the page.

A large area of the page is reserved for writing, featuring a vertical solid line on the left side and horizontal dotted lines extending across the page.

OCR

Oxford Cambridge and RSA

Copyright Information

OCR is committed to seeking permission to reproduce all third-party content that it uses in its assessment materials. OCR has attempted to identify and contact all copyright holders whose work is used in this paper. To avoid the issue of disclosure of answer-related information to candidates, all copyright acknowledgements are reproduced in the OCR Copyright Acknowledgements Booklet. This is produced for each series of examinations and is freely available to download from our public website (www.ocr.org.uk) after the live examination series.

If OCR has unwittingly failed to correctly acknowledge or clear any third-party content in this assessment material, OCR will be happy to correct its mistake at the earliest possible opportunity.

For queries or further information please contact The OCR Copyright Team, The Triangle Building, Shaftesbury Road, Cambridge CB2 8EA.

OCR is part of Cambridge University Press & Assessment, which is itself a department of the University of Cambridge.