

Please check the examination details below before entering your candidate information

Candidate surname

Other names

Centre Number

Candidate Number

--	--	--	--	--

--	--	--	--	--

Pearson Edexcel Level 1/Level 2 GCSE (9–1)

Friday 9 June 2023

Afternoon (Time: 1 hour 10 minutes)

Paper
reference

1SC0/2BH

Combined Science
PAPER 4

Higher Tier

You must have:

Ruler, calculator

Total Marks

Instructions

- Use **black** ink or ball-point pen.
- **Fill in the boxes** at the top of this page with your name, centre number and candidate number.
- Answer **all** questions.
- Answer the questions in the spaces provided
– *there may be more space than you need.*

Information

- The total mark for this paper is 60.
- The marks for **each** question are shown in brackets
– *use this as a guide as to how much time to spend on each question.*
- In questions marked with an **asterisk** (*), marks will be awarded for your ability to structure your answer logically, showing how the points that you make are related or follow on from each other where appropriate.

Advice

- Read each question carefully before you start to answer it.
- Try to answer every question.
- Check your answers if you have time at the end.

Turn over ►

P72561A

©2023 Pearson Education Ltd.
N:1/1/



Pearson

DO NOT WRITE IN THIS AREA

DO NOT WRITE IN THIS AREA

DO NOT WRITE IN THIS AREA

BLANK PAGE



Answer ALL questions. Write your answers in the spaces provided.

Some questions must be answered with a cross \boxtimes . If you change your mind about an answer, put a line through the box \boxtimes and then mark your new answer with a cross \boxtimes .

- 1 People with diabetes cannot always control the concentration of glucose in their blood.

(a) Two people eat identical meals.

One person has diabetes, the other person does not have diabetes.

Figure 1 shows the concentration of glucose in the blood of these two people after eating the meals.

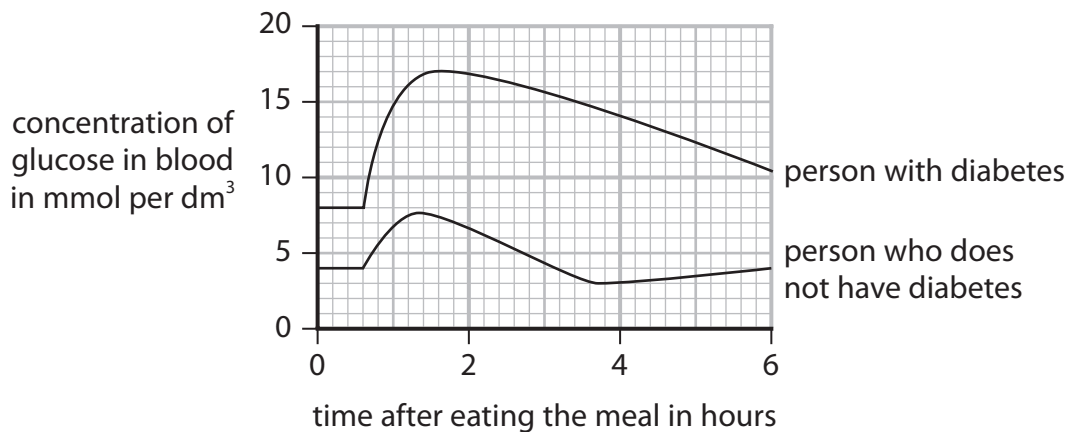

Figure 1

- (i) Calculate the maximum increase in the concentration of glucose in the blood of the person with diabetes.

(1)

..... mmol per dm^3

- (ii) Water moved out of the red blood cells of the person with diabetes when the concentration of glucose in the blood was above 15 mmol per dm^3 .

Explain why water moved out of the red blood cells of the person with diabetes.

(2)

.....

.....

.....

.....



(b) The pancreas produces a hormone that causes the concentration of glucose in the blood to decrease.

(i) Name this hormone.

(1)

(ii) State how this hormone is transported from the pancreas to its target organs.

(1)

(iii) Which is the target organ for the hormone that controls the concentration of glucose in the blood?

(1)

- A** kidney
- B** pancreas
- C** liver
- D** lung

(c) Explain how type 2 diabetes can be controlled.

(3)

(Total for Question 1 = 9 marks)



2 Respiration occurs in cells.

(a) Why do cells respire?

(1)

- A to produce nitrogen
- B to release oxygen
- C to produce glucose
- D to release energy

(b) An athlete runs every day as part of their training.

(i) Explain why the breathing rate of the athlete increases when running.

(2)

.....

.....

.....

.....

.....

(ii) When the athlete is running, their muscle cells use both aerobic respiration and anaerobic respiration.

State **two** differences between aerobic respiration and anaerobic respiration.

(2)

1

.....

.....

.....

2

.....

.....



(c) Bromothymol blue (BTB) solution is an indicator of pH.

Figure 2 shows the colour of BTB at different pH levels.

pH	4	5	6	7 (neutral)	8
colour	yellow	yellowy green	light green	green	blue

Figure 2

When air is passed through green BTB, for one minute, the solution stays green.

When a person breathes out through a straw into BTB for one minute the solution turns yellow.

(i) Explain why the air breathed out turns the BTB solution yellow.

(2)

.....

.....

.....

.....



- (ii) A scientist placed pondweed into two sealed test tubes containing green BTB solution.

Test tube A was kept in the dark.

Test tube B was kept in the light.

All other conditions were kept the same.

Figure 3 shows these test tubes at the start of the investigation.

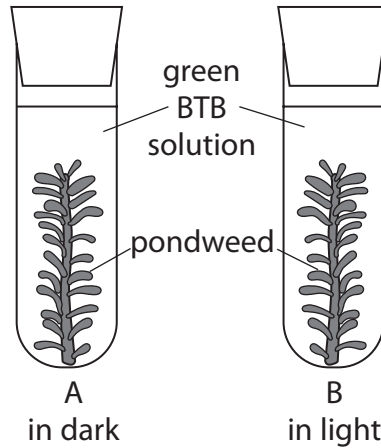

Figure 3

Figure 4 shows the colour of the BTB solution after 5 hours.

Tube A (in dark)	Tube B (in light)
yellowy green	green

Figure 4

Explain the results for tube A and tube B shown in Figure 4.

(2)

.....

.....

.....

.....

.....

(Total for Question 2 = 9 marks)



DO NOT WRITE IN THIS AREA

DO NOT WRITE IN THIS AREA

DO NOT WRITE IN THIS AREA

BLANK PAGE



3 A student investigated the effect of light intensity on the photosynthesis of pondweed.

A light source was placed at different distances from the pondweed.

The bubbles produced were counted for 2 minutes.

Figure 5 shows the apparatus that was used.

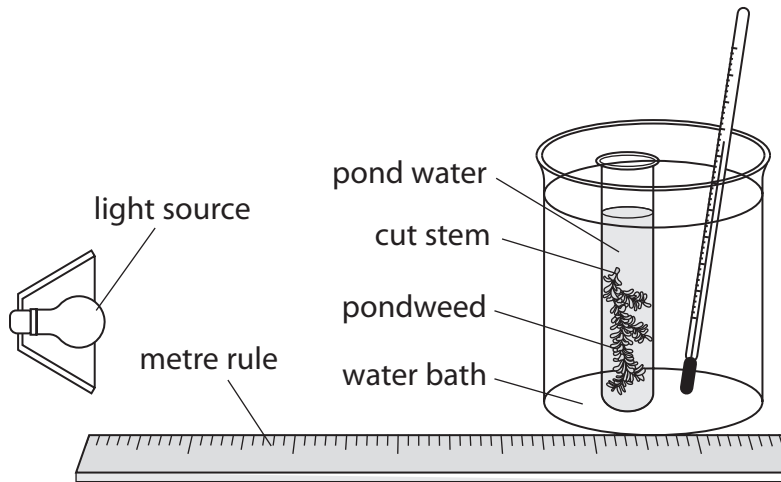

Figure 5

(a) (i) State why the student included a water bath in the apparatus.

(1)

.....

.....

(ii) State **two** variables that should be controlled when completing this investigation.

(2)

1

.....

2

.....



(b) Figure 6 shows the results of this investigation.

distance from the lamp in cm	number of bubbles in two minutes	light intensity in arbitrary units
5	62	0.04
10	60	0.01
15	43	0.0044
20	32	0.0025
25	11	?

Figure 6

- (i) The light intensity was calculated using the inverse square law for photosynthesis.

Calculate the light intensity at a distance of 25 cm from the lamp.

Include the equation for the inverse square law in your answer.

(3)

..... arbitrary units

- (ii) Explain how the student could improve this investigation to get a more accurate measurement of the gas produced.

(2)

.....

.....

.....

.....



(c) Devise a plan to show that temperature is a limiting factor in photosynthesis.

Use the apparatus shown in Figure 5.

(3)

.....

.....

.....

.....

.....

.....

.....

.....

.....

(Total for Question 3 = 11 marks)

DO NOT WRITE IN THIS AREA

DO NOT WRITE IN THIS AREA

DO NOT WRITE IN THIS AREA



4 Gas exchange happens in the alveoli in the lungs.

Figure 7 shows an alveolus and a capillary.

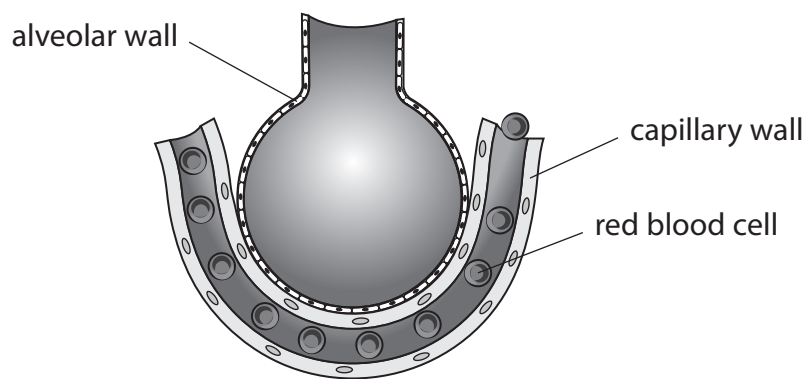

(adapted from : sciencepics/shutterstock)

Figure 7

(a) (i) Name the gas used in respiration that moves from the alveolus into the capillary.

(1)

(ii) Name the gas produced by respiration that moves from the capillary into the alveolus.

(1)

(iii) The capillary wall is only one cell thick.

Explain how gases move from the alveolus to the capillary.

(3)



(iv) Explain the advantages of red blood cells passing one at a time through this narrow capillary.

(3)

.....

.....

.....

.....

.....

.....

(b) The average number of alveoli in each human lung is 280 million.

The surface area of 1 million alveoli is 0.25 m^2 .

Calculate the total surface area of a human lung.

(2)

.....

(Total for Question 4 = 10 marks)

DO NOT WRITE IN THIS AREA

DO NOT WRITE IN THIS AREA

DO NOT WRITE IN THIS AREA



DO NOT WRITE IN THIS AREA

DO NOT WRITE IN THIS AREA

DO NOT WRITE IN THIS AREA

BLANK PAGE



DO NOT WRITE IN THIS AREA

DO NOT WRITE IN THIS AREA

DO NOT WRITE IN THIS AREA

5 Figure 8 shows the changes in the levels of the hormones of the menstrual cycle.

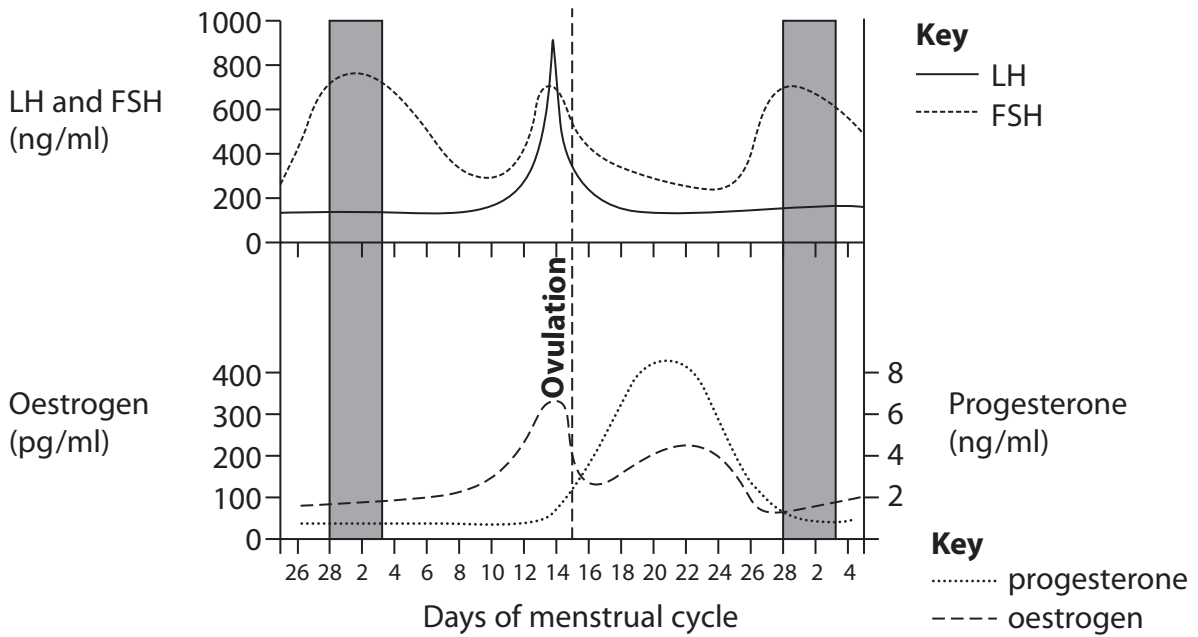

Figure 8

(a) (i) The maximum concentration of oestrogen is just before ovulation.

Which is the maximum concentration of oestrogen?

(1)

- A 8 ng/ml
- B 210 pg/ml
- C 320 pg/ml
- D 900 ng/ml

(ii) Explain how **two** of the hormones shown in Figure 8 cause ovulation.

(3)

.....

.....

.....

.....

.....

.....

.....



(iii) State the number of days for the first menstruation shown in Figure 8.

(1)

(iv) Explain how the levels of each hormone in the woman shown in Figure 8 would be different, if she was pregnant.

(4)

(Total for Question 5 = 9 marks)

DO NOT WRITE IN THIS AREA

DO NOT WRITE IN THIS AREA

DO NOT WRITE IN THIS AREA



6 Figure 9 shows a photomicrograph of two stomata in a leaf.

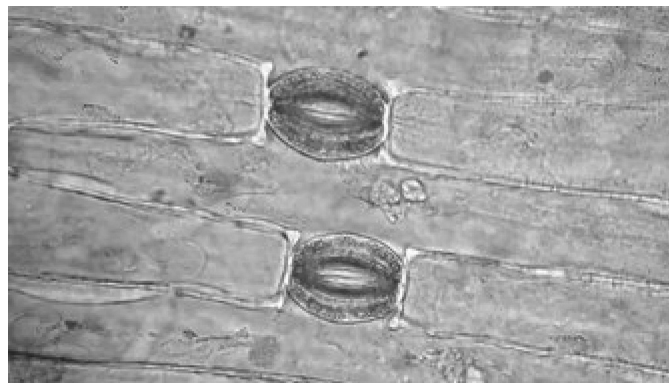

Figure 9

(a) (i) The length of one guard cell in this image is 6 mm.

Convert the length of this guard cell into micrometres (μm).

(1)

(ii) The image has been magnified 150 \times .

Calculate the actual size of the guard cell.

Give your answer in standard form in mm.

(3)

..... mm

(b) Explain the role of denitrifying bacteria in the nitrogen cycle.

(2)

.....

.....

.....

.....

.....



*(c) Describe how carbon is cycled through the biotic and abiotic components of an ecosystem.

(6)

DO NOT WRITE IN THIS AREA

DO NOT WRITE IN THIS AREA

DO NOT WRITE IN THIS AREA

(Total for Question 6 = 12 marks)

TOTAL FOR PAPER = 60 MARKS



DO NOT WRITE IN THIS AREA

DO NOT WRITE IN THIS AREA

DO NOT WRITE IN THIS AREA

BLANK PAGE



P 7 2 5 6 1 A 0 1 9 2 0

DO NOT WRITE IN THIS AREA

DO NOT WRITE IN THIS AREA

DO NOT WRITE IN THIS AREA

BLANK PAGE

