

Emanuel School

13+ science test

Sample entrance examination paper

First name

Last name

Remember

- The test is 1 hour long.
- You will need: pen, pencil, rubber, ruler, protractor and calculator.
- The test starts with easier questions.
- Try to answer all the questions.
- Write all your answers on the test paper, do not use rough paper.
- Check your work carefully.
- Ask your teacher if you are not sure what to do.

Good luck!

Emanuel School

Battersea Rise London SW11 1HS

Telephone: 020 8870 4171

e-mail enquiries@emanuel.org.uk

1. This is Jamie having an X-ray of his arm.

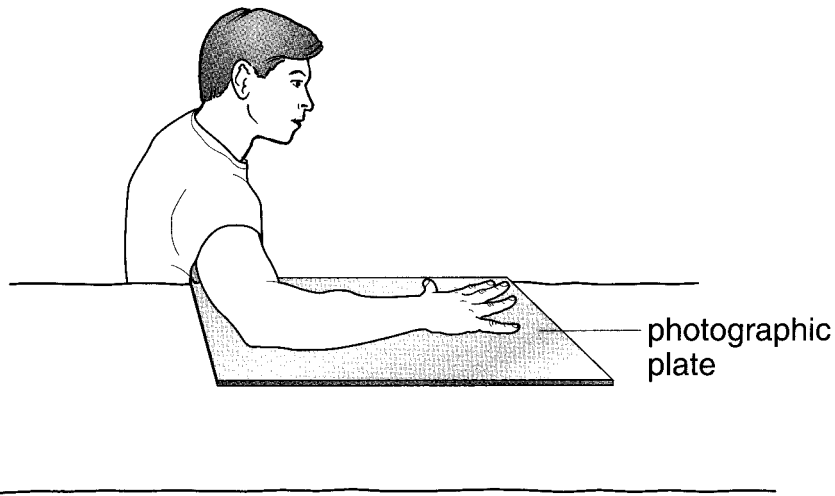

The drawing below shows the X-ray photograph.

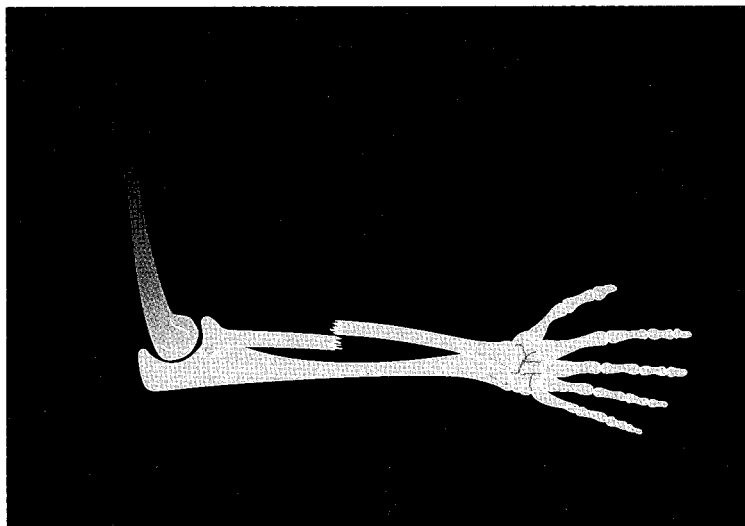

(a) Complete the sentence.

The parts of Jamie's arm which show up on the X-ray are made of

1 mark

(b) What did the X-ray photograph show had happened to Jamie's arm?

1 mark

(c) Jamie drew the following diagram of parts of his arm.

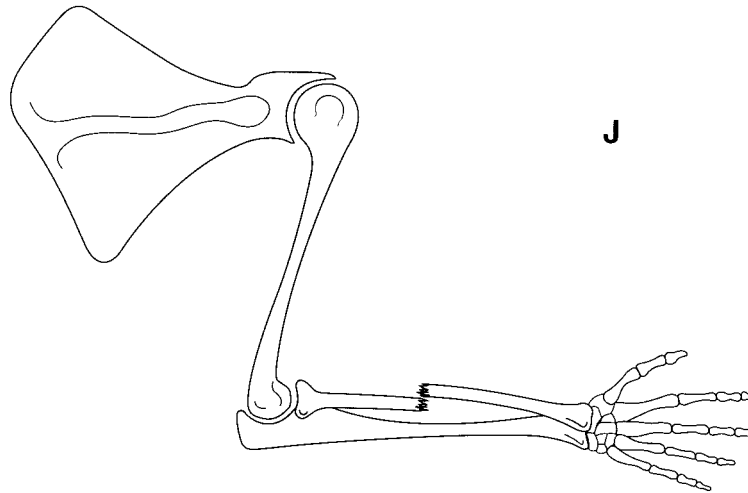

(i) On the diagram, draw a line from the letter J to a joint in the arm.

1 mark

(ii) Why are joints needed in the arm?

1 mark

(iii) The parts which contract to move the arm do **not** show up on an X-ray. What are these parts called? Tick the correct box.

1 mark

blood vessels

glands

muscles

skin

maximum 5 marks

2. The drawing shows a horseshoe bat.

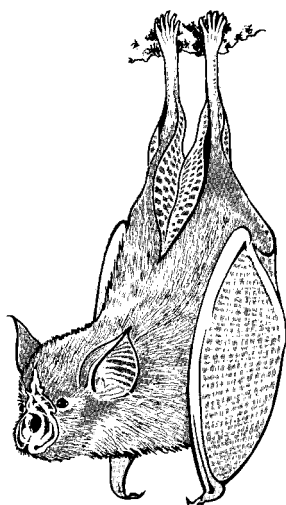

In an investigation, Val counted the number of insects a horseshoe bat ate. Her results are shown below.

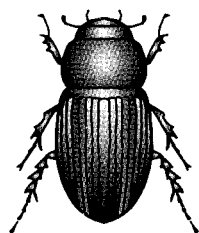

A
35 dung beetles

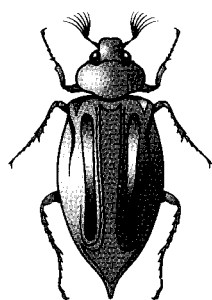

B
10 cockchafers

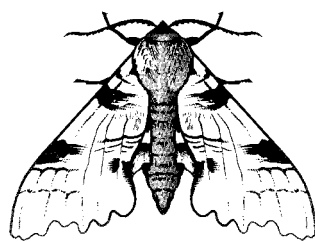

C
40 moths

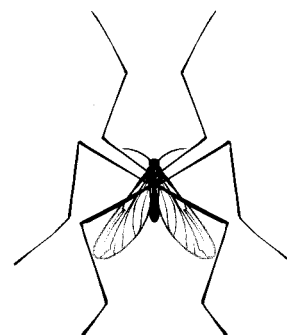

D
15 other insects

not to scale

- (a) Val used the numbers of insects to draw a pie chart.
Write the letter of each insect by the correct section of the pie chart.

3 marks

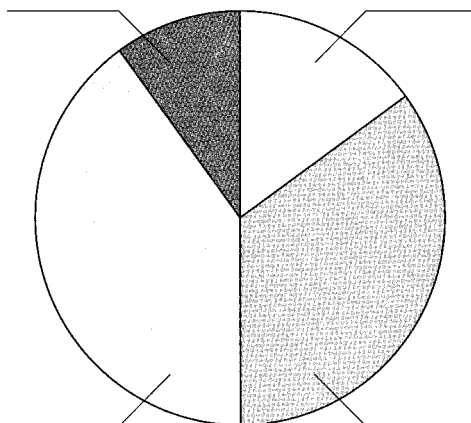

(b) Dung beetles eat dung (animal droppings).

(i) Why are there lots of dung beetles in fields where cows are kept?

1 mark

(ii) Why do horseshoe bats live close to fields where cows are kept?

1 mark

(c) (i) Insecticides are used to kill insects.

What will happen to the number of horseshoe bats if the insects are killed?

1 mark

(ii) Give **one** other reason why the number of horseshoe bats might change.

1 mark

maximum 7 marks

-
3. Rhododendron plants grow bigger and faster than other plants.
The drawing below shows a man cutting down rhododendron plants.

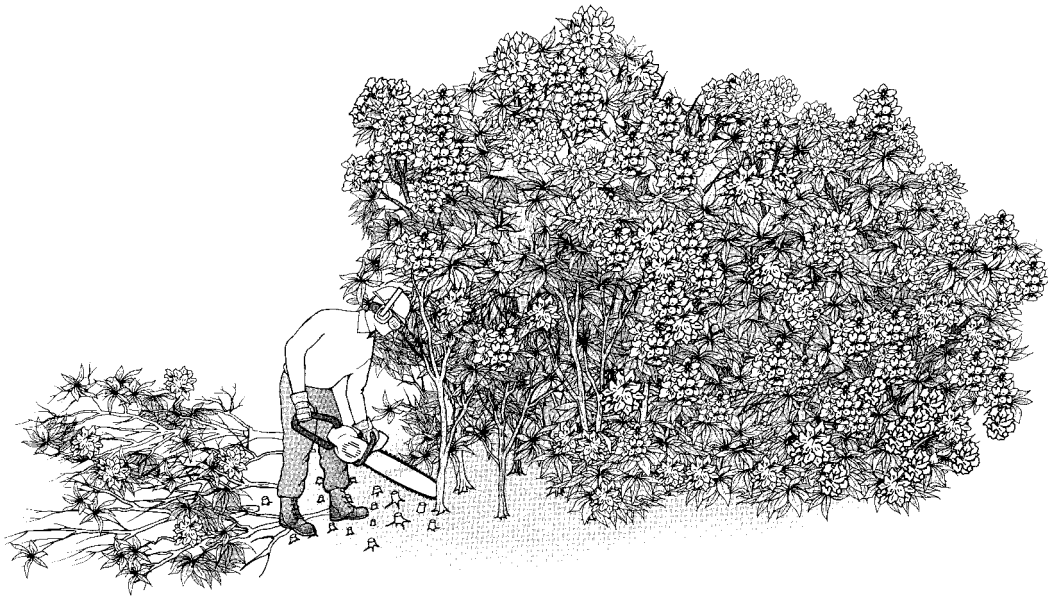

- (a) (i) Scientists think the rhododendron roots might produce a chemical that stops other plants growing nearby.
Why does this help rhododendrons to grow?

1 mark

- (ii) Give another reason why hardly any other plants can grow under the rhododendron bushes.

1 mark

- (b) After the rhododendrons and their roots are cleared away there will not be any of the chemical in the soil.
What will happen to the number of other plants growing there?

1 mark

(c) The drawing shows an insect called a weevil.

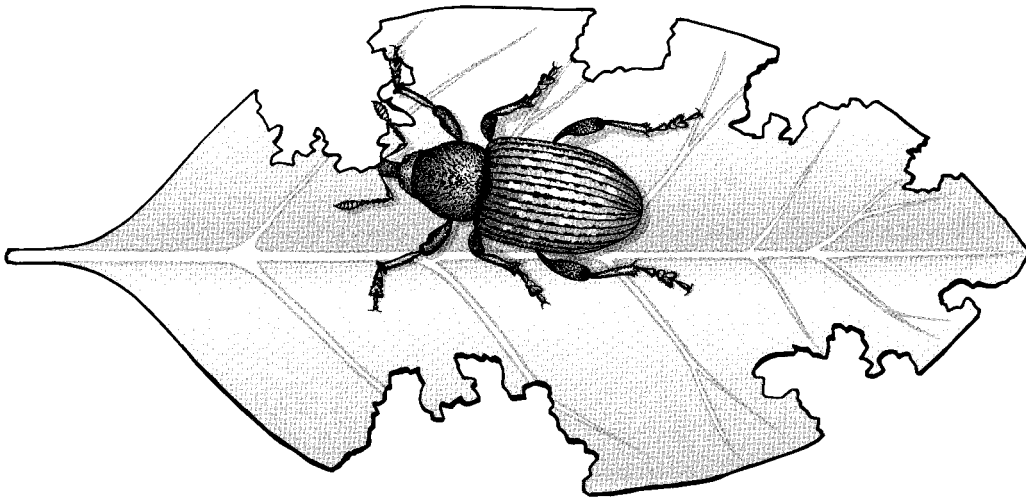

Weevils feed on the leaves of rhododendrons.

Draw a line from the rhododendron box to the word that describes the rhododendron.

Draw a line from the weevil box to the word that describes the weevil.

2 marks

rhododendron (plant)

carnivore

herbivore

predator

weevil (insect)

producer

maximum 5 marks

4. (a) The table below shows the melting points of four metals.

metal	melting point, in °C
gold	1064
mercury	-37
sodium	98
iron	1540

(i) Which metal in the table has the highest melting point?

1 mark

(ii) Which metal in the table has the lowest melting point?

1 mark

(b) Gold can be a **gas** or a **liquid** or a **solid**.

Choose from these words to fill the gaps below.

1 mark

When gold is heated from room temperature to 1070°C, the gold

changes from a _____ to a _____

- (c) 5 g of gold is melted and **all** of it is poured into a mould to make a pendant as shown below.

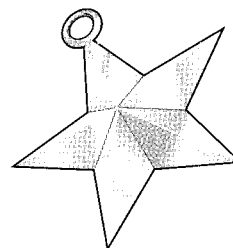
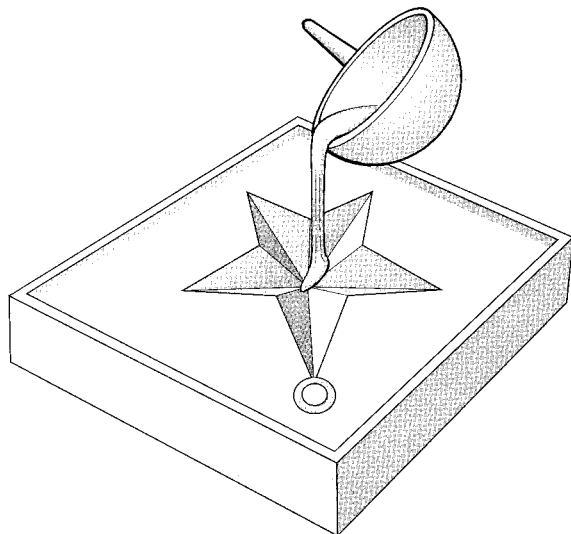

gold pendant

melted gold is poured into a mould

What is the mass of the gold pendant?

_____ g

1 mark

- (d) The table below shows how the four metals react with oxygen when heated in air.

metal	reaction when heated in air
gold	no change
mercury	slowly forms a red powder
sodium	bursts into flames straight away
iron	very slowly turns black

- (i) Which is the **most** reactive metal in the table?

1 mark

- (ii) Which is the **least** reactive metal in the table?

1 mark

maximum 6 marks

-
5. These photographs show how the cliffs on the coastline by a church changed between the years 1886 and 1919.



the church and
coastline in 1886

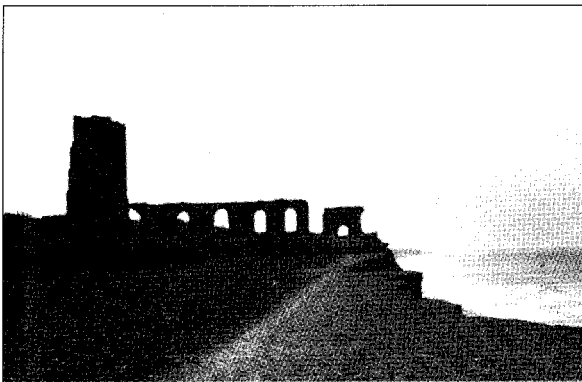

the church and
coastline in 1904

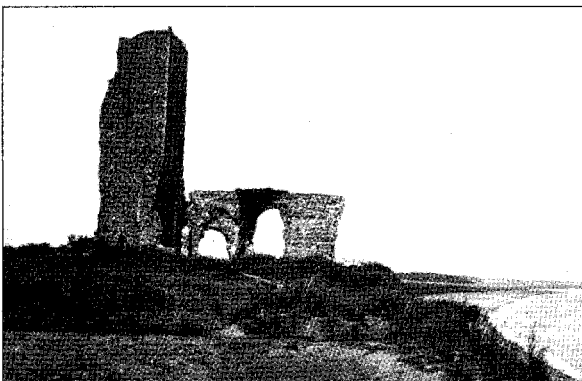

the church and
coastline in 1912

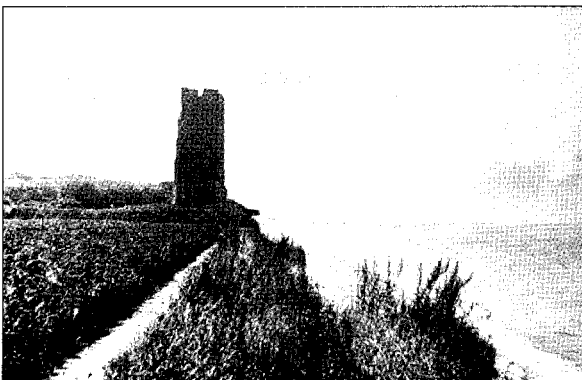

the church and
coastline in 1919

(a) (i) How can you tell from the photographs that the coastline has changed?

1 mark

(ii) What made the coastline change? Tick the correct box.

1 mark

the rain	<input type="checkbox"/>	the sea	<input type="checkbox"/>
the Sun	<input type="checkbox"/>	the wind	<input type="checkbox"/>

(b) On the seashore, pebbles that are rough and uneven become smooth and rounded. Explain how they become smooth and rounded.

1 mark

(c) The photograph below shows a carved limestone head. The surface of the limestone has changed over many years.



(i) Which process made the surface of the limestone change over many years? Tick the correct box.

1 mark

carving	<input type="checkbox"/>	polishing	<input type="checkbox"/>
melting	<input type="checkbox"/>	weathering	<input type="checkbox"/>

(ii) Name a substance in the air which made the surface of the limestone change.

1 mark

maximum 5 marks

-
6. Kala recorded temperatures using a datalogger and three temperature sensors, P, Q and R. The ends of the sensors were covered with gauze. P was kept dry. Q was dipped in water for 2 seconds and then taken out. R was dipped in ethanol for 2 seconds and then taken out.

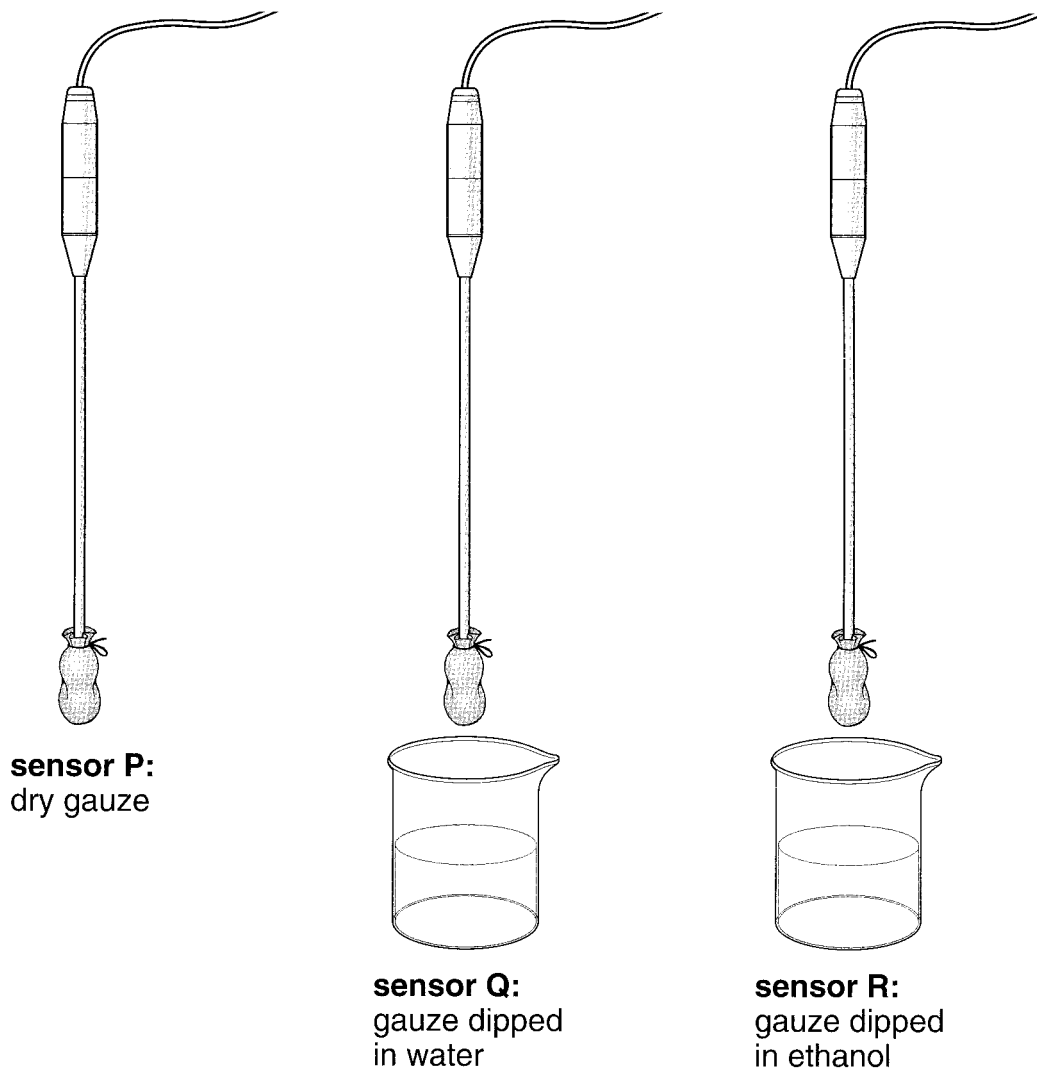

Every five minutes, the datalogger recorded the temperatures of the sensors.

time, in min	temperature of sensor P, in °C	temperature of sensor Q, in °C	temperature of sensor R, in °C
0	20	20	20
5	20	18	16
10	20	17	12
15	20	17	20

- (a) What was the temperature of the room at the beginning of Kala's experiment?

_____ °C

1 mark

- (b) Describe how the temperatures of sensor Q and sensor R changed.

sensor Q _____

sensor R _____

2 marks

- (c) The next day the gauze on sensor Q felt dry.
What had happened to the water on the gauze?

1 mark

maximum 4 marks

7. Nikki tries to set up four electric circuits.

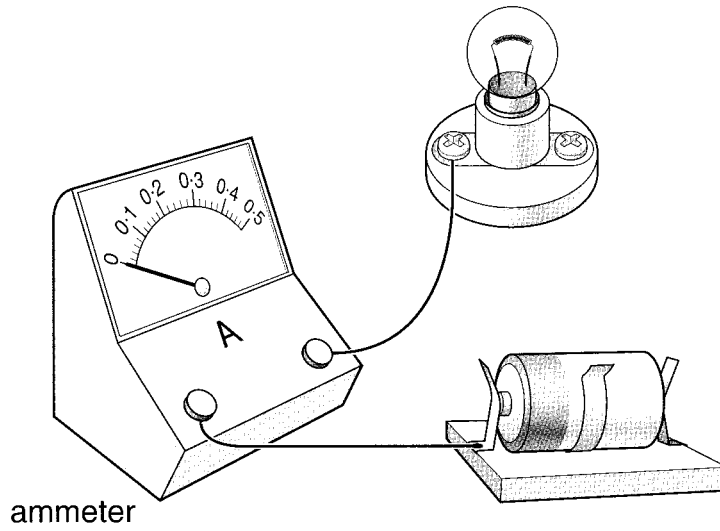

diagram 1

(a) In diagram 1 the ammeter reading is zero. What is wrong with this circuit?

1 mark

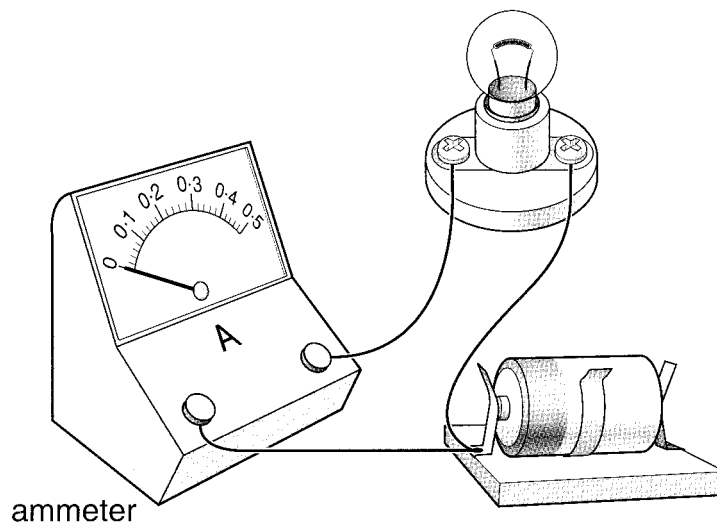

diagram 2

(b) In diagram 2 the ammeter reading is zero. What is wrong with this circuit?

1 mark

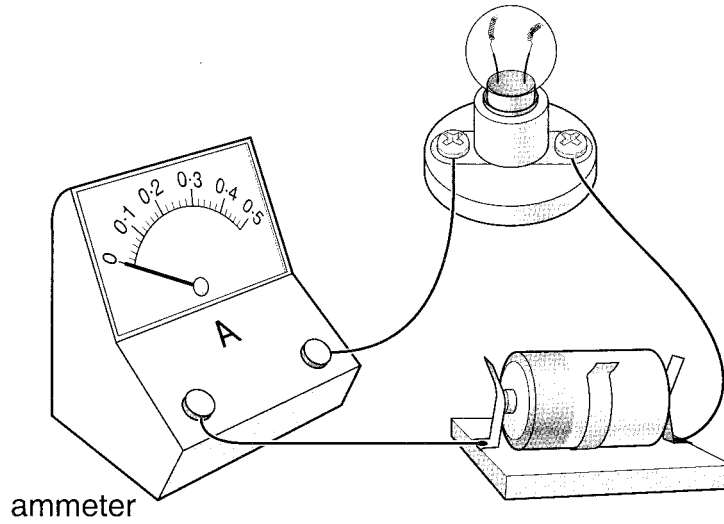

diagram 3

- (c) In diagram 3 the ammeter reading is zero. Why is this **not** a complete circuit?

1 mark

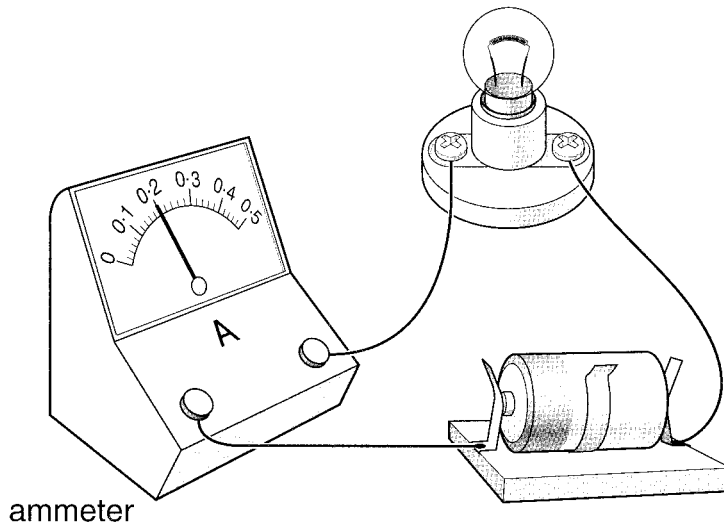

diagram 4

- (d) In diagram 4, why is there a reading on the ammeter?

1 mark

maximum 4 marks

8. Tom tries on four types of footwear in a sports shop.

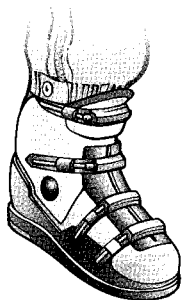

ski boot

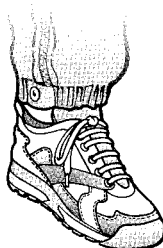

trainer



ice skate



walking boot

- (a) (i) When Tom tries on the footwear, which one sinks into the carpet the most?

1 mark

- (ii) When Tom tries on the footwear, what is the same for each type of footwear? Tick the correct box.

1 mark

the area of the footwear

Tom's weight on the footwear

the material of the footwear

the weight of the footwear

(b) The drawing below shows a snowshoe.

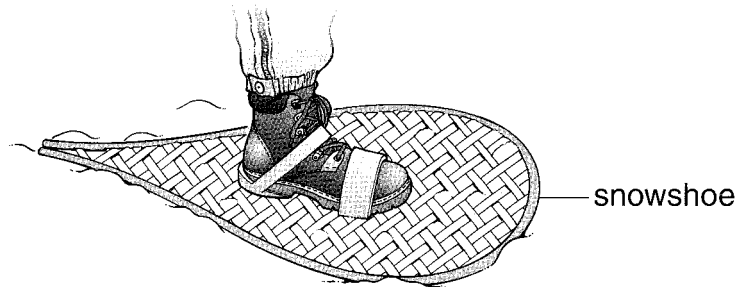

How do snowshoes help people to walk in deep snow?

1 mark

(c) Choose the correct word from the list to complete the sentence below.

air resistance friction gravity magnetism

1 mark

When Tom is ice skating the force of _____

between the skate and the ice is less than when he is walking on a carpet.

maximum 4 marks

- (c) Loudness is measured in decibels. The table below shows the loudness of some sounds.

sound	loudness, in decibels
whispering	20
normal talking	60
disco	100
road drill	120
space rocket taking off	190

Jasmine's balloon bursts.

What would be the most likely range of loudness of the sound produced when the balloon bursts?

Tick the correct box.

1 mark

- below 60 decibels
- 60–120 decibels
- 120–190 decibels
- above 190 decibels

- (d) (i) Very loud sounds can damage a person's ears.
In what way can the ears be damaged?

1 mark

- (ii) Some people work in very noisy places.
How can they protect their ears?

1 mark

maximum 5 marks

10. The table shows the recommended daily intake of energy and some of the nutrients needed by different groups of people.

group of people	energy, in kJ	nutrients				
		protein, in g	carbohydrate, in g	fat, in g	minerals, in mg	
					calcium	iron
male 15–18	11510	55.2	360	109	1000	11.3
female 15–18	8830	45.0	276	84	800	14.8
male 19–50	10600	55.5	331	100	700	8.7
female 19–50	8100	45.0	253	77	700	14.8
pregnant female	8900	81.0	278	84	700	14.8

(a) (i) Explain why two 16 year-old males of the same weight might need different amounts of energy.

1 mark

(ii) Which **two** types of nutrient provide most of the energy in our diet?

2 marks

1. _____

2. _____

(b) (i) Calculate the difference in the recommended daily intake of calcium for a 15 year-old male and a 30 year-old male.

1 mark

_____ mg

(ii) Calcium is needed for healthy bones. Explain the difference in the amount of calcium needed each day by a 15 year-old male and a 30 year-old male.

1 mark

-
- (c) Look at the table. Explain the difference in the amount of protein needed by a 25 year-old pregnant female and a 25 year-old female who is **not** pregnant.

1 mark

- (d) Iron is needed to make blood.
Explain why a 15 year-old female might need more iron than a 15 year-old male.

1 mark

maximum 7 marks

11. The diagram shows a section through the human female reproductive system.

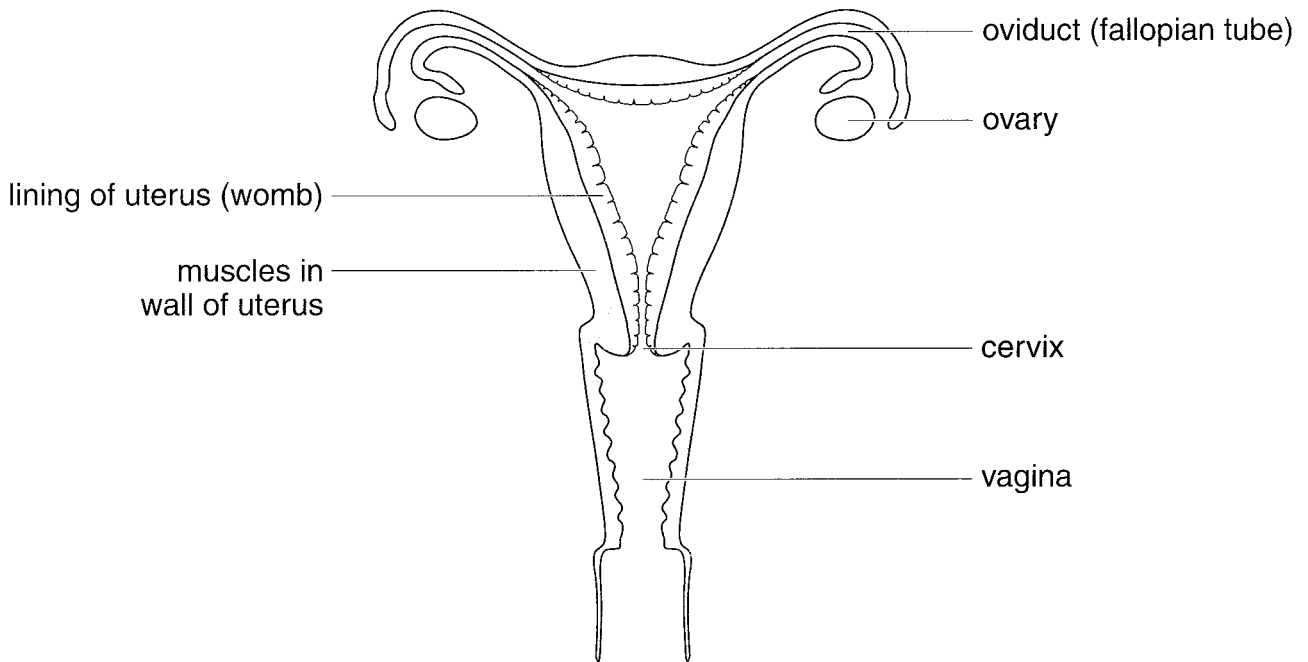

- (a) (i) How often are eggs normally released in the female reproductive system?

1 mark

- (ii) In which labelled part is an egg normally fertilised by a sperm?

1 mark

- (b) Fill the **two** gaps in the sentences below.

2 marks

A fertilised egg divides into a tiny ball of cells called an embryo.

The embryo attaches to the lining of the uterus. Here the embryo

grows to become an unborn baby, called a _____ .

It takes about _____ months for a baby to develop

inside its mother.

(c) The diagram below shows a baby growing in its mother's uterus.

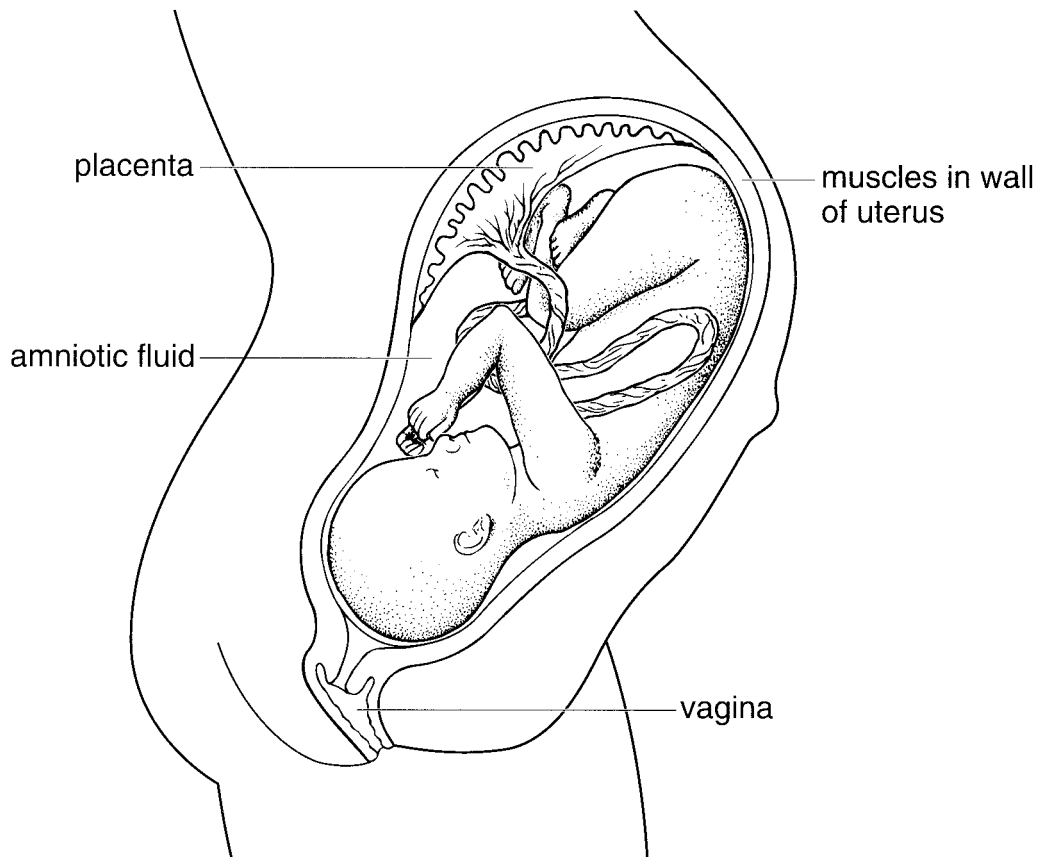

(i) What is the function of the amniotic fluid?

1 mark

(ii) Through which part can harmful substances, such as nicotine, pass from the mother's blood to the baby's blood?

1 mark

(iii) Give **one other harmful** substance which may be passed from the mother's blood to the baby's blood.

1 mark

(d) When the baby is born it is pushed out of the mother's body. What happens in the wall of the uterus to push the baby out?

1 mark

maximum 8 marks

12. A teacher set up the following apparatus to separate the chemicals in cigarette smoke.
The chemicals pass through the apparatus in the direction of the arrows.

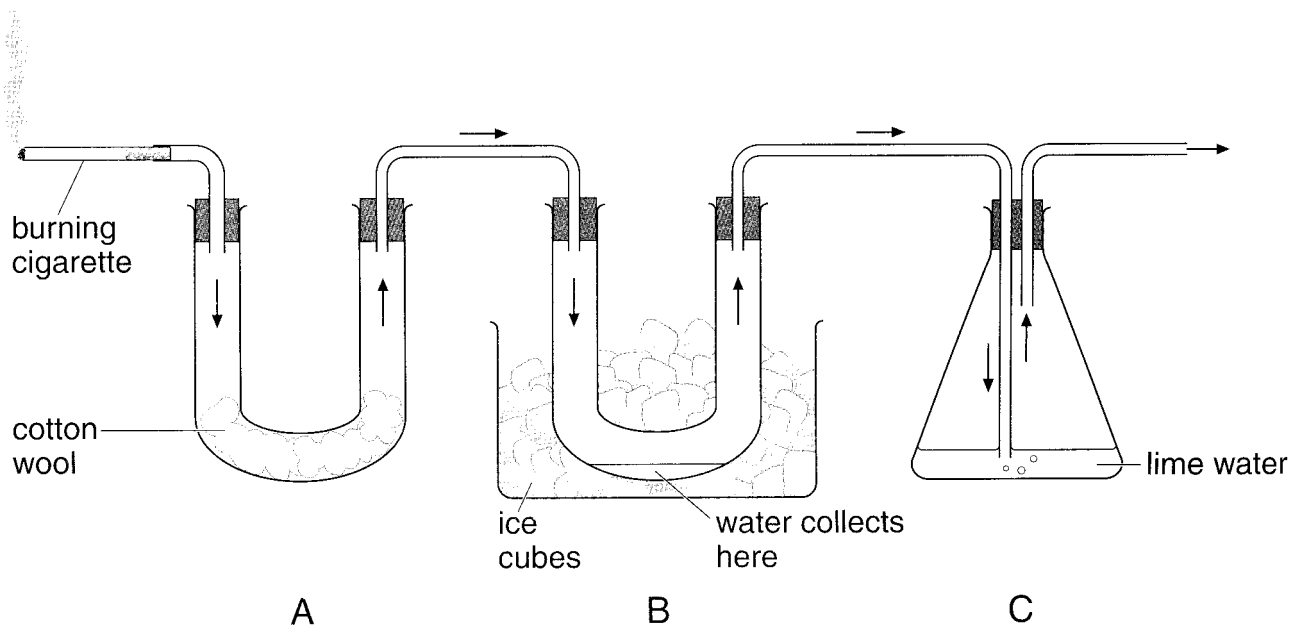

- (a) In A, a brown sticky substance collected on the cotton wool.
This substance causes lung cancer.
Give the name of the brown substance.
- (b) As the cigarette burned, water vapour was produced and water collected in B.
- (i) Why were ice cubes needed in B?

1 mark

1 mark

-
- (ii) In the boxes below, draw the arrangement of particles of water vapour and particles of liquid water.

Use a circle, ○, to represent each particle.

2 marks

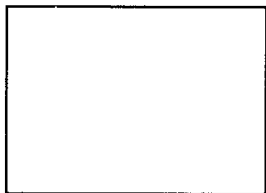

particles of
water vapour

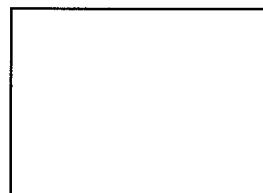

particles of
liquid water

- (c) The lime water in C became cloudy. What gas turns lime water cloudy?

1 mark

maximum 5 marks

13. Ben put a beaker weighing 50 g on a balance. He added 50 g of dilute hydrochloric acid and 2.5 g of calcium carbonate to the beaker. The total mass of the beaker and its contents was 102.5 g.

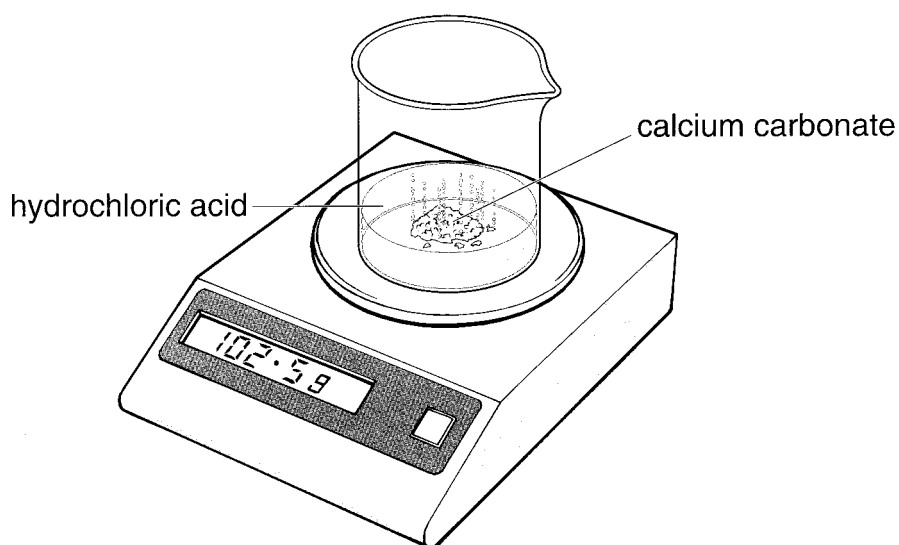

- (a) The hydrochloric acid reacted with the calcium carbonate. How could Ben tell that a chemical reaction was taking place in the beaker?

1 mark

- (b) The word equation for the reaction which took place is:

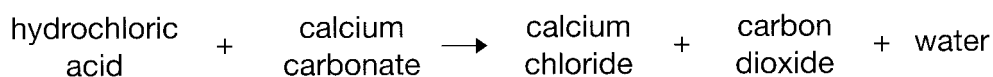

When the reaction stopped, the total mass had decreased from 102.5 g to 101.4 g.

Some water had evaporated from the beaker.

What else caused the drop in mass?

Use the word equation to help you answer the question.

1 mark

-
- (c) When the reaction stopped, Ben tested the contents of the beaker with universal indicator paper. The calcium carbonate had neutralised the acid. What is the colour of universal indicator paper in a neutral solution?

1 mark

- (d) Which **two** materials in the list below are mainly calcium carbonate? Tick the **two** correct boxes.

2 marks

coal	<input type="checkbox"/>
glass	<input type="checkbox"/>
limestone	<input type="checkbox"/>
marble	<input type="checkbox"/>
sandstone	<input type="checkbox"/>

- (e) Metals react with acids.
What gas is produced when a metal reacts with an acid?

1 mark

maximum 6 marks

14. At school Ellen heated some copper powder until it went black.

- (a) Give the name of the black substance formed when copper reacts with oxygen.

1 mark

- (b) Ellen added the black substance to some dilute sulphuric acid. The black substance reacted with sulphuric acid forming a blue solution of copper sulphate.

What type of substance is copper sulphate?

Tick the correct box.

1 mark

an acid	<input type="checkbox"/>	a compound	<input type="checkbox"/>
an element	<input type="checkbox"/>	a mixture	<input type="checkbox"/>

- (c) (i) Ellen poured 20 cm³ of the blue copper sulphate solution into a dish, A, as shown below.

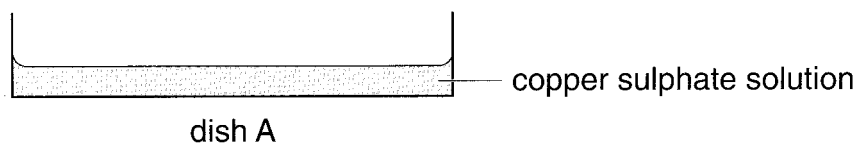

She left the dish in a room at 21°C for two days.

What **two** changes would Ellen observe in dish A two days later?

2 marks

1. _____

2. _____

-
- (ii) Ellen poured 20 cm³ of the same blue copper sulphate solution into another dish, B. She put a lid on dish B and left it in the room at 21°C for two days.

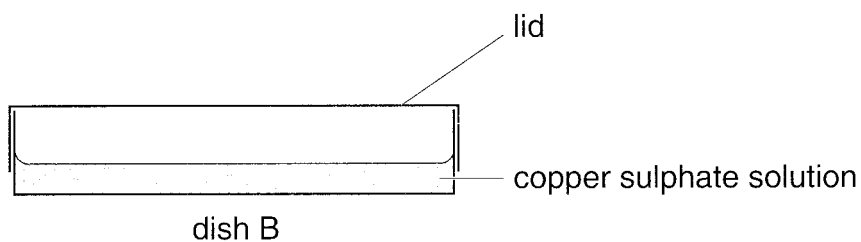

After two days the contents of dish B looked different from the contents of dish A.

Give **one** difference Ellen would observe and explain how the lid caused this difference.

2 marks

maximum 6 marks

15. Luke investigated the heating of water. He predicted that the rise in temperature would depend on the volume of water. The diagram shows the apparatus he used.

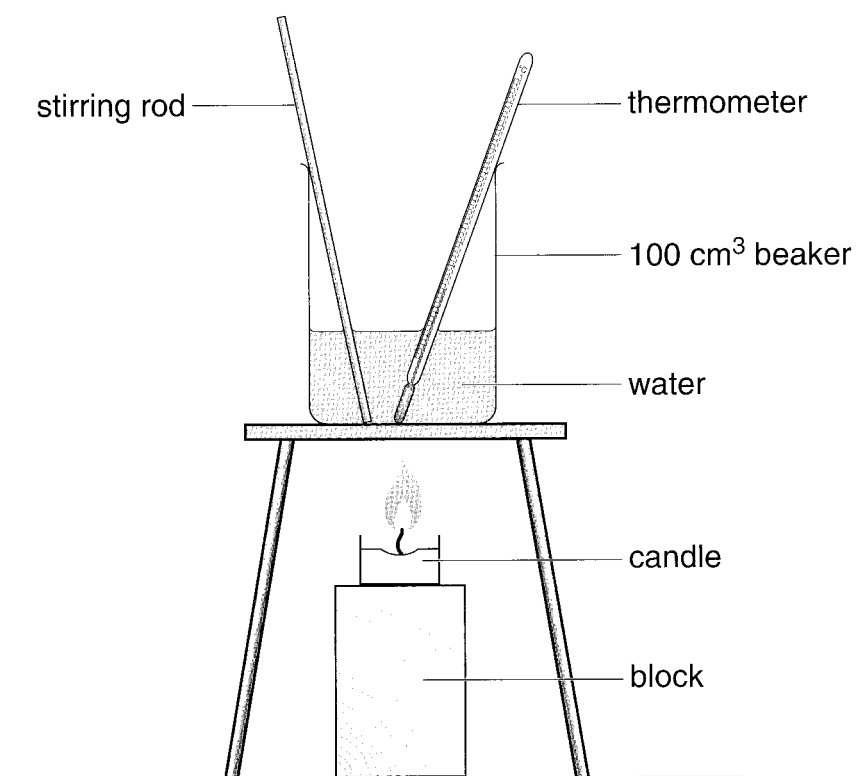

Luke recorded his results in a table as shown below.

beaker	volume of water, in cm ³	temperature at start, in °C	temperature after 2 minutes, in °C
A	25	18	30
B	50	18	24
C	75	18	22

- (a) Why did Luke need to know the temperature of the water at the beginning and at the end of the experiment?

1 mark

-
- (b) Did Luke's results support his prediction?
Explain your answer.

1 mark

- (c) Luke stirred the water during the experiment.
How did this make his results more reliable?

1 mark

- (d) Which of the following statements about the energy transferred to the beakers is correct?
Tick the correct box.

1 mark

Much more energy went into beaker 'A'
because its temperature increased the most.

The same amount of energy went into all
three beakers.

Beaker 'C' received the most energy
because there was more water to heat.

- (e) After a time, all three beakers cooled down to room temperature.
What happened to the thermal energy in the beakers as they cooled
down?

1 mark

maximum 5 marks

16. The table shows the time taken for the Earth, Mars and Venus to orbit the Sun.

planet	time taken to orbit the Sun, in Earth years
Earth	1.0
Mars	1.9
Venus	0.6

The diagram shows the orbits of the Earth, Mars and Venus round the Sun, at one particular time. The arrows show the direction in which the planets move.

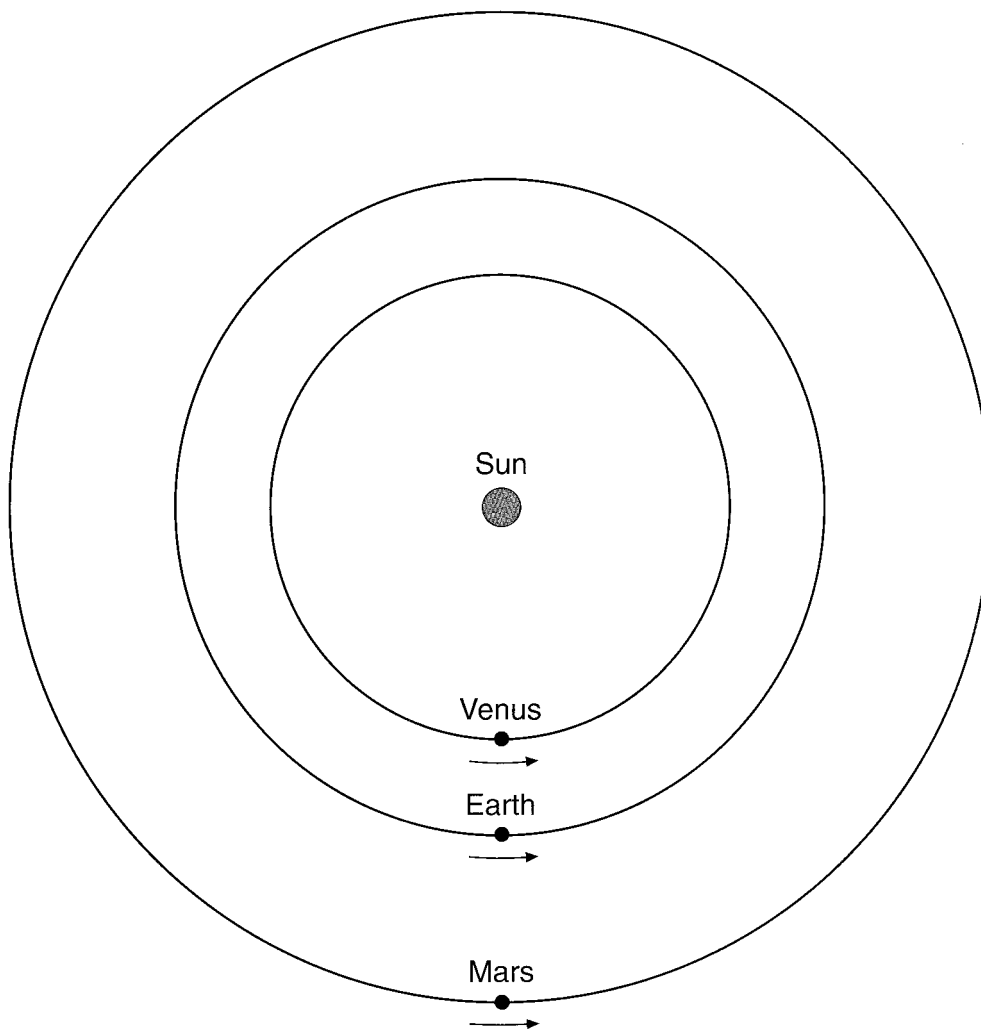

not to scale

At the time shown in the diagram, the three planets were lined up with the Sun.

(a) Show the position of the Earth **three** months after the planets were lined up, by marking a point on the Earth's orbit.
Label the point E. 1 mark

(b) (i) Show the approximate position of Mars **three** Earth months after the planets were lined up, by marking a point on Mars's orbit.
Label the point M. 1 mark

(ii) Explain why Mars is in this position. 1 mark

(c) (i) Show the approximate position of Venus **three** Earth months after the planets were lined up, by marking a point on Venus's orbit.
Label the point V. 1 mark

(ii) Explain why Venus is in this position. 1 mark

maximum 5 marks

17. Sarah made a cotton reel vehicle like the one shown in the diagram.
The pencil is wound round and round so that it winds up the rubber band.
A piece of candle wax next to the cotton reel lets the rubber band slowly unwind.

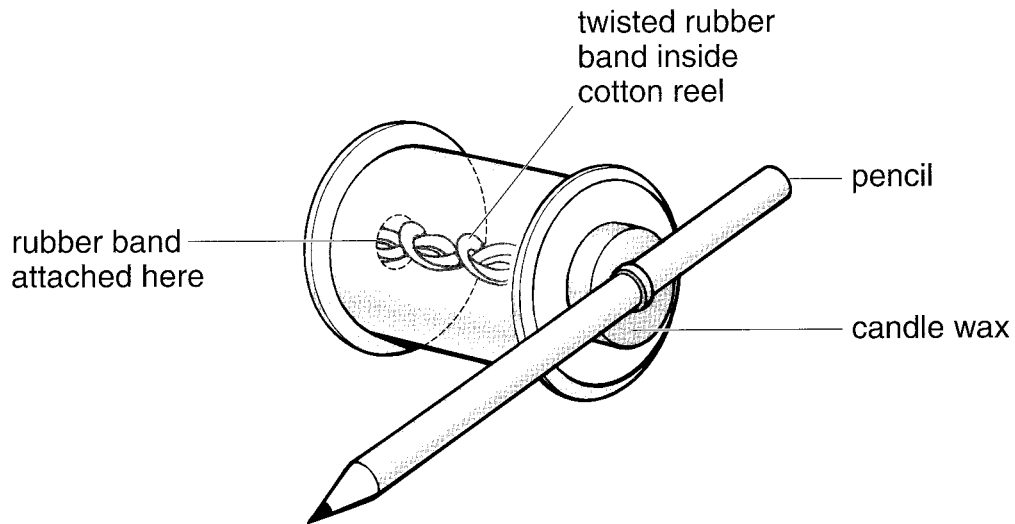

- (a) As the rubber band unwinds, the candle wax slips and the cotton reel turns.
Name the force which acts between the cotton reel and the candle wax.

1 mark

- (b) Sarah tested the vehicle by letting it run along a horizontal table top.

- (i) She noticed that the vehicle gradually slowed down.
Give the reason for this.

1 mark

- (ii) Describe what Sarah could do to make the rubber band move this vehicle faster.

1 mark

maximum 3 marks