



# Year 9 Entrance and Scholarship Examination Mathematics

## Specimen Paper A

**TIME allowed for this paper: 90 minutes**

### **Instructions**

- Use a calculator where appropriate.
- Answer all the questions.
- Show all your working.
- Marks for questions are shown in square brackets [ ].
- There are 100 marks in total
- You must not write in the squares at the bottom right of each page

1. Use your calculator to work out the value of:

$$\frac{3^2 + 4^3}{4 + \sqrt{5}}$$

(a) writing down all the digits of your answer from your calculator,

Answer: \_\_\_\_\_ [1]

(b) correct to 2 decimal places,

Answer: \_\_\_\_\_ [1]

(c) correct to 5 significant figures.

Answer: \_\_\_\_\_ [1]

---

2. Below is a sequence of numbers:

$$15, 8, 1, -6, \dots$$

Calculate the:

(a) 7<sup>th</sup> term of this sequence,

Answer: \_\_\_\_\_ [1]

(b) 100<sup>th</sup> term of this sequence.

Answer: \_\_\_\_\_ [2]

---

**Page total:**

3. A shop is currently selling a games console for £245.

The shop buys the console from the manufacturers for £175.

(a) Calculate the percentage profit that the shop makes.

Answer: \_\_\_\_\_ % [2]

The shop needs to add on VAT (Value Added Tax) at 20% to the current selling price.

(b) Calculate the new selling price of the games console, i.e. including VAT.

Answer: £ \_\_\_\_\_ [2]

The shop also sells games for this games console. Each game has a selling price, including VAT, of £18. A student is entitled to a student discount of 7% off any games purchased.

(c) Calculate how much the student will pay for 5 games.

Answer: £ \_\_\_\_\_ [2]

---

**Page total:**

4. Calculate the value of  $A$  and  $B$  in the following:

(a)  $\frac{4}{5} - \frac{A}{15} = \frac{2}{15}$

Answer:  $A =$  \_\_\_\_\_ [2]

(b)  $\frac{3}{7} \div \frac{B}{11} = \frac{11}{7}$

Answer:  $B =$  \_\_\_\_\_ [2]

---

5. Expand and simplify the following:

(a)  $5(4x + 8)$

Answer: \_\_\_\_\_ [2]

(b)  $a(a - 3b) - 4b(2a - 5)$

Answer: \_\_\_\_\_ [3]

(c)  $(2x + 4)(3x - 7)$

Answer: \_\_\_\_\_ [3]

---

Page total:

6. A pack of 40 cards is made up of red and black cards. The probability that a red card is chosen at random is  $\frac{3}{8}$ . Calculate how many black cards there are in the pack.

Answer: \_\_\_\_\_ [2]

---

7. (a) The angles in a triangle are in the ratio 10 : 3 : 5. Calculate the size of the largest angle.

Answer: \_\_\_\_\_ [2]

- (b) The ratio of Mark's age to Chris's age is 3 : 4. Calculate how old Chris is if he is 7 years older than Mark.

Answer: \_\_\_\_\_ [2]

---

<b>Page total:</b>
--------------------

8. An L shape is drawn on the graph below:

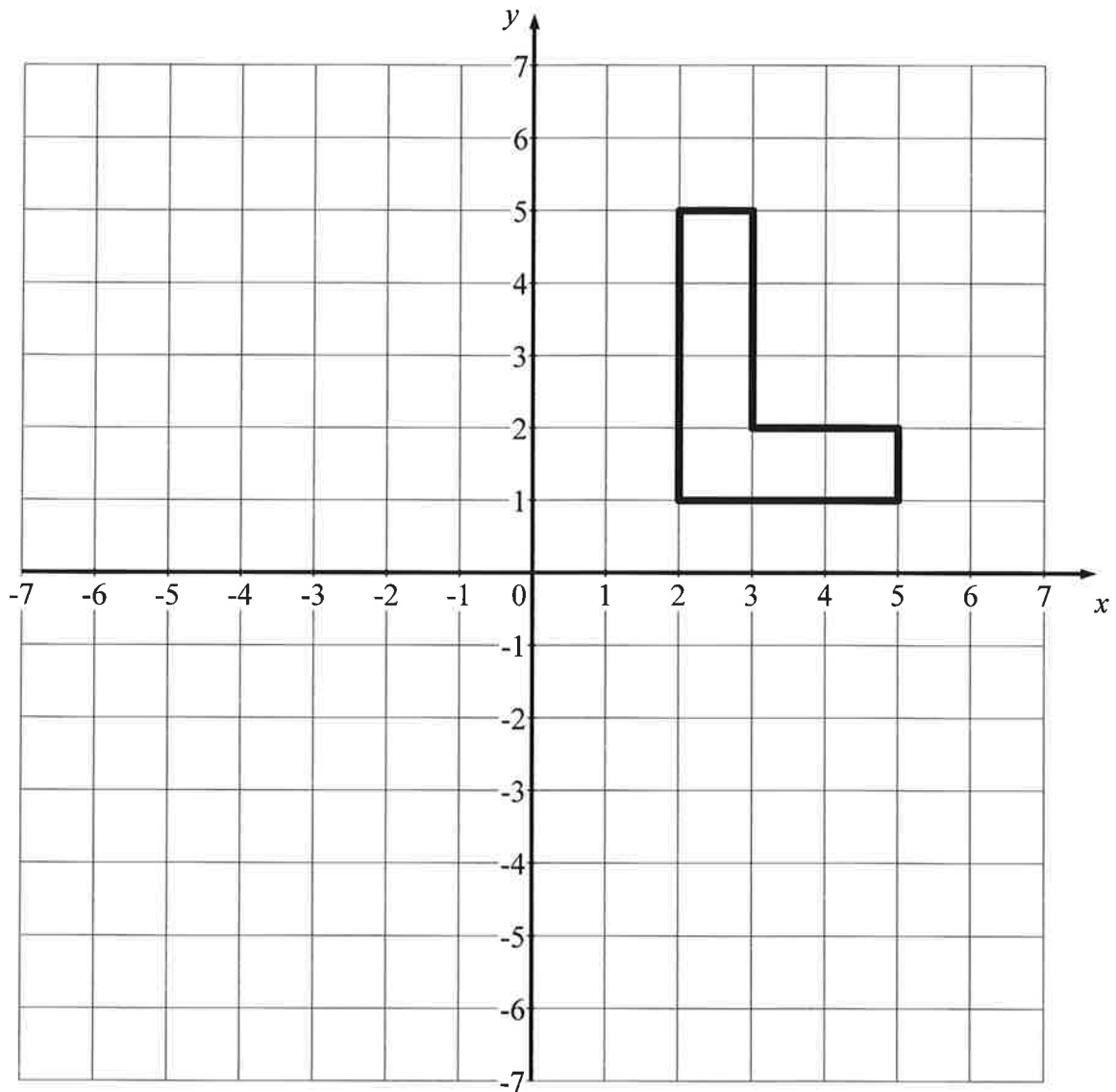

On the graph draw the result of:

- (a) reflecting the L shape in the  $x$  axis labelling this shape A, [2]
- (b) rotating the **original** L shape  $90^\circ$  anticlockwise about the point  $(-1, 0)$  labelling this shape B, [2]
- (c) translating the **original** L shape by the vector  $\begin{pmatrix} -6 \\ -7 \end{pmatrix}$  labelling this shape C. [2]

9. The diagram below shows 3 right angled triangles. Calculate the lengths marked  $x$  and  $y$ , giving your answers to 3 significant figures where appropriate.

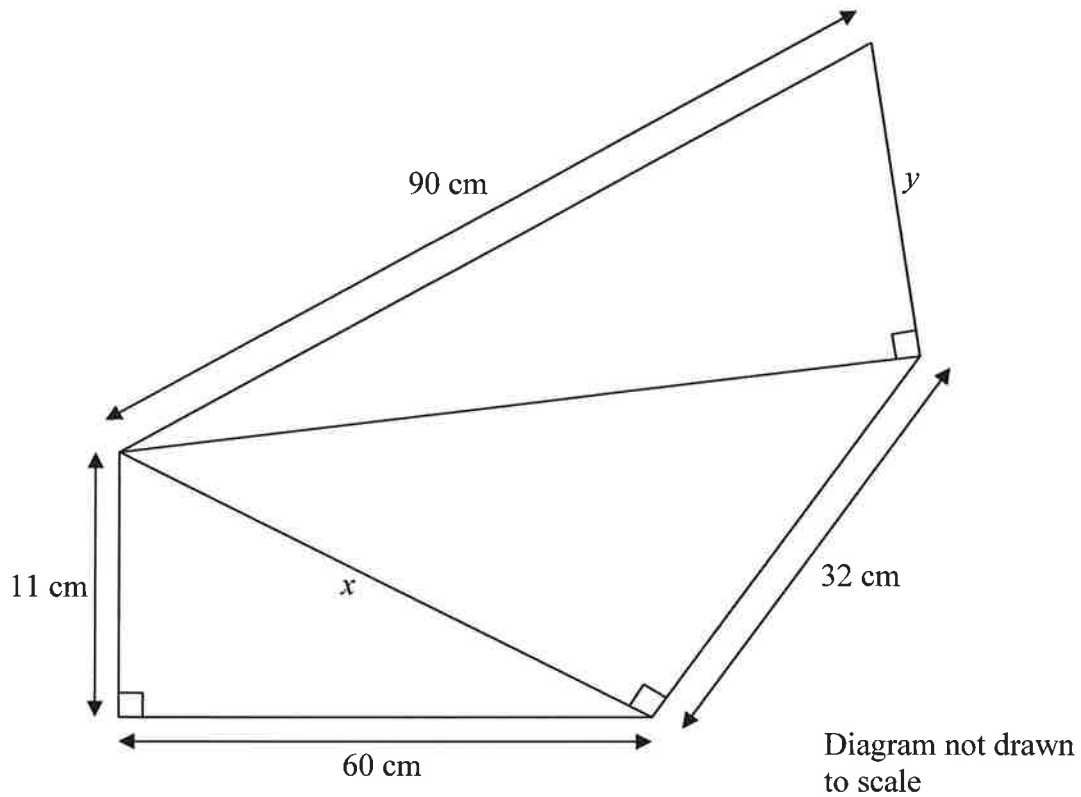

Answer:  $x =$  \_\_\_\_\_  $y =$  \_\_\_\_\_ [4]

---

10. Factorise  $49xy^2 + 21xy$

Answer: \_\_\_\_\_ [2]

---

11. (a) The test scores of six students were:

5, 7, 0, 5, 17, 8

Calculate the mode, median and mean for these test scores.

mode = \_\_\_\_\_, median = \_\_\_\_\_, mean = \_\_\_\_\_ [4]

(b) The total weight of 5 rugby players is 425 kg and the mean weight of 10 badminton players is 50.5 kg. Calculate the mean weight of all 15 players.

Answer: \_\_\_\_\_ kg [3]

(c) The mean age of three people is 22 years old and their median age is 20. The range of their ages is 16 years. Calculate the age of the youngest person.

Answer: \_\_\_\_\_ [3]

---

<b>Page total:</b>
--------------------



12. Solve the following equations for  $x$ :

(a)  $3x - 5 = 5x + 6$

$x =$  \_\_\_\_\_ [2]

(b)  $4(2x - 6) = 3x$

$x =$  \_\_\_\_\_ [2]

(c)  $\frac{2x}{5} = -8$

$x =$  \_\_\_\_\_ [2]

(d)  $(x + 2)(x - 5) = x(x - 7)$

$x =$  \_\_\_\_\_ [3]

---

**Page total:**

--

13. The diagram below shows an overlapping triangle and parallelogram, with the parallel lines indicated by the arrows. Calculate the size of the angles marked  $x$  and  $y$

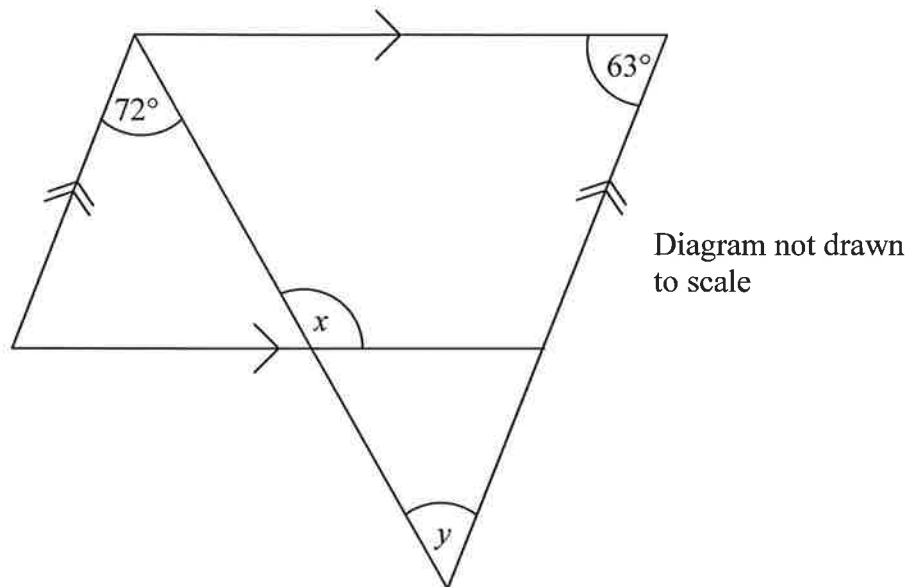

Answer:  $x =$  \_\_\_\_\_  $y =$  \_\_\_\_\_ [3]

14. The diagram below shows a regular polygon.

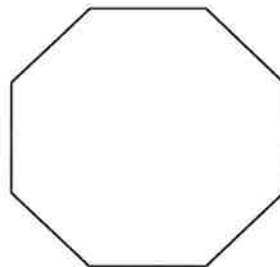

Diagram not drawn to scale

- (a) Write down the name of this polygon.

Answer: \_\_\_\_\_ [1]

- (b) Calculate the size of the interior and exterior angles for this polygon.

Answer: interior angle = \_\_\_\_\_, exterior angle = \_\_\_\_\_ [4]

15. The diagram below shows a triangular based prism. The triangle forming the base is a right angled triangle. The volume of this prism is  $108 \text{ cm}^3$ .

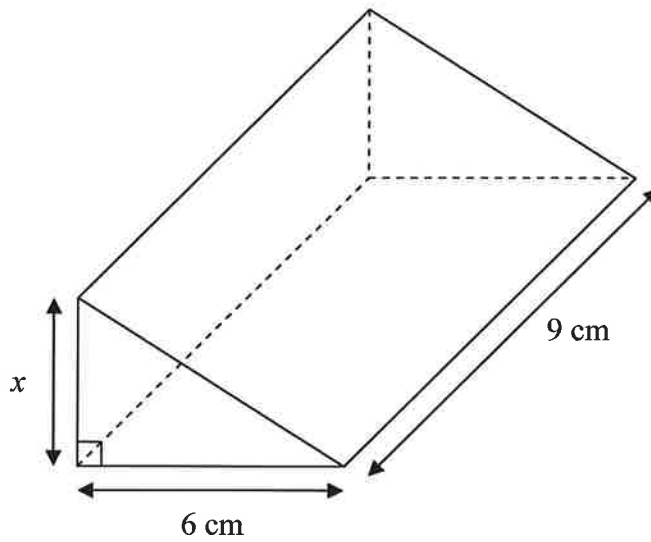

Diagram  
not drawn  
to scale

Calculate the value of  $x$ .

Answer: \_\_\_\_\_ cm [3]

Page total:

16. After a test there are 180 test papers to be marked. It would take Adam 30 minutes to mark all the papers whilst it would take Brian 45 minutes to mark them all.

(a) Calculate how many test papers Adam marks per minute.

Answer: \_\_\_\_\_ [2]

(b) Calculate how many minutes it would take them to mark the papers if they did so together.

Answer: \_\_\_\_\_ minutes [3]

---

17. The diagram below shows a square divided by three equally spaced horizontal lines and a single diagonal line. Calculate the fraction of the square which is shaded.

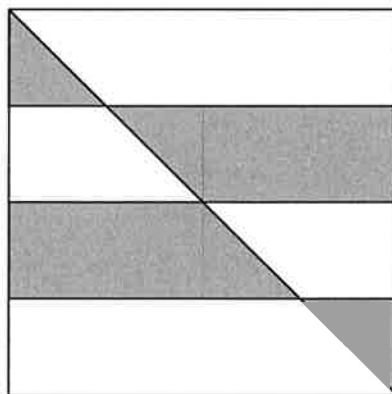

Fraction of square shaded: \_\_\_\_\_ [2]

---

Page total:

--

18. The diagram below shows 3 intersecting lines.

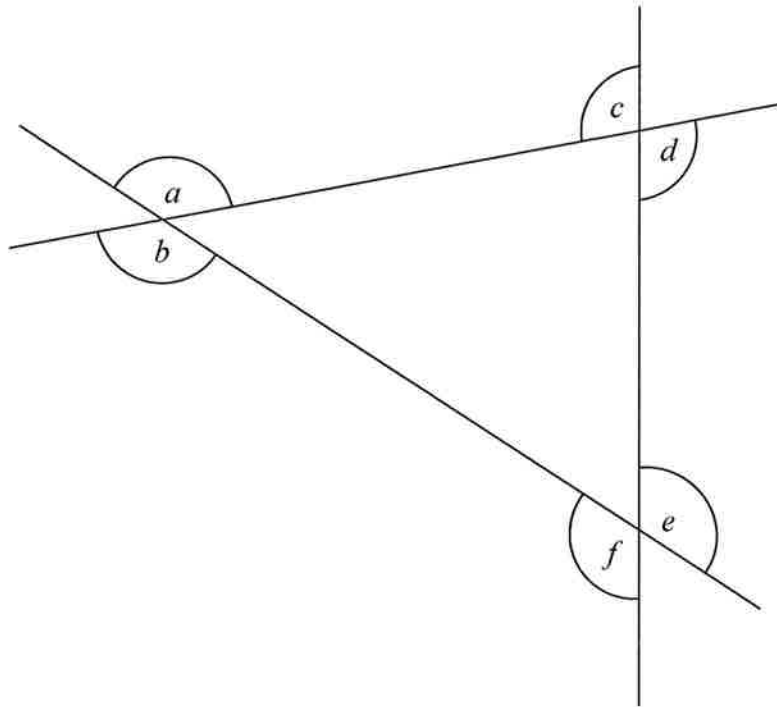

Calculate the value of  $a + b + c + d + e + f$ .

Answer: \_\_\_\_\_ [2]

---

19. Find the biggest number which is less than 50 and is the product of three different prime numbers.

Answers: \_\_\_\_\_ [2]

---

Page total:

--

20. The shape below is formed by a straight line of length 20 cm and two quarter circles with the same radius.

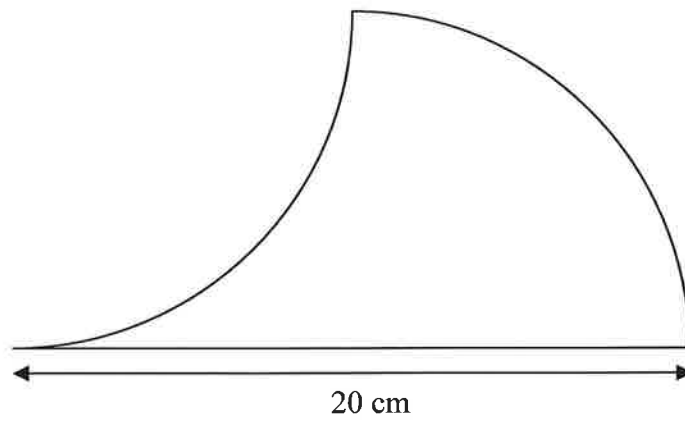

Diagram  
not drawn  
to scale

For the above shape calculate, to 3 significant figures, the:

- (a) perimeter,

Answer: \_\_\_\_\_ cm [3]

- (b) area.

Answer: \_\_\_\_\_ cm<sup>2</sup> [3]

---

Page total:

21. The diagram below shows 2 overlapping squares with regions  $A$ ,  $B$  and  $C$  as shown. Calculate the difference between the areas of the regions  $A$  and  $C$ .

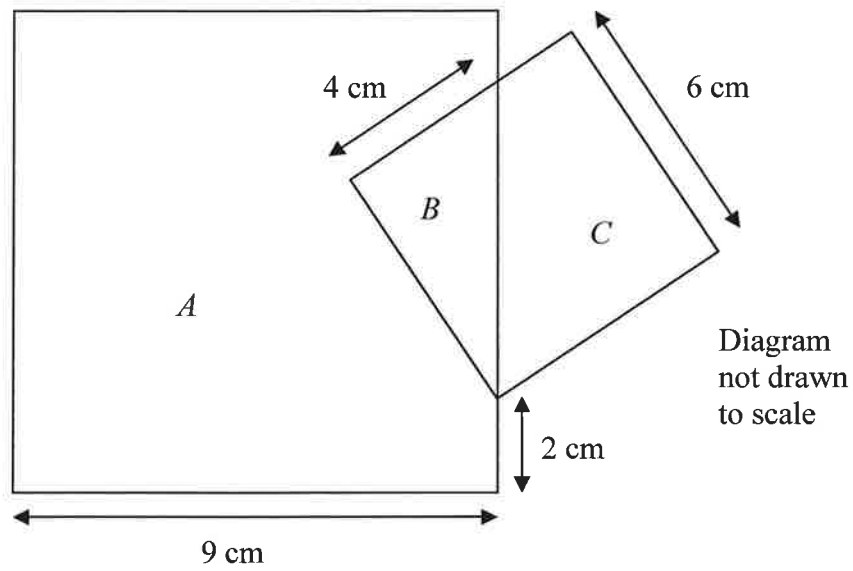

Answer: \_\_\_\_\_  $\text{cm}^2$  [3]

22. The diagram below shows a square contained within a circle which is contained inside another square. The length of each side for the smaller square is  $\sqrt{8}$  cm.

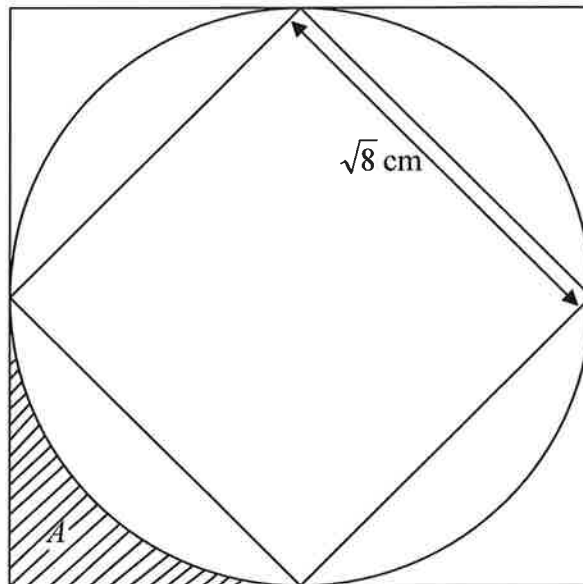

Diagram  
not drawn  
to scale

Calculate the perimeter of the shaded area A, writing your answer to 3 significant figures.

Answer: \_\_\_\_\_ cm [4]



23. (a) All of the students who study A-level Mathematics at a particular school decide to go on a march. They find that if they walk in pairs, i.e. two students in each row, then there is one student left in the back row. They find similarly that if they walk with three students in each row then there is still one student left in the back row, and that if they walk with four in each row then there is still one student left in the back row.

Calculate the minimum number of students that there could be who study A-level Mathematics at this school.

Answer: \_\_\_\_\_ [2]

- (b) Inspired by the Mathematics students' march, all of the students in the school decide to go on a march the following week. In the same way, if all of the students walk in pairs then there is one student left in the back row, but now they find that whether they walk in threes, fours, fives, sixes, sevens, eights or nines, they always have one student left in the back row.

Calculate the minimum number of students who could be at the school in total.

Answer: \_\_\_\_\_ cm [2]

**THE END**  
**IF YOU HAVE TIME THEN GO BACK AND CHECK YOUR ANSWERS**

**Page total:**