

13+



Dulwich College

YEAR 9 ENTRANCE AND SCHOLARSHIP
EXAMINATION

SAMPLE PAPER

Mathematics

1 HOUR 30 MINUTES

Use a calculator where appropriate.

Answer all the questions.

Show all your working.

Marks for parts of questions are shown in square brackets [].

13+ Syllabus Summary for Mathematics

The entrance exam consists of a 1½ hour written paper. Candidates should be familiar with most of the skills and knowledge of Key Stage 3 Mathematics. Topics covered are largely from up to level 6 (with some elements of level 7).

However, the emphasis is more on testing the ability to think rather than just knowledge, i.e. there will be several questions on 'easy' topics which require a willingness to think and persevere with a problem.

Arithmetic

Four basic operations for fractions, percentages, decimals, negative numbers. Ratios. Prime numbers and prime factors. Square and cube numbers. Rounding. Use of a calculator.

Algebra

Sequences. Construction of formulae. Collecting like terms, multiplying out brackets, remove common factors. Solving linear equations, simultaneous equations, inequalities. Plotting linear and quadratic graphs, solving equations using graphs. Simple algebraic fractions.

Geometry

Symmetry. Transformations. Areas and volumes of shapes, including prisms. Geometric facts for polygons. Pythagoras's Theorem. Loci.

Statistics

Mean, mode and median and range. Scatter plots, pie charts, line graphs. Probability

1. In a sale, prices are reduced by 15%. The normal price of a camera is £140. Calculate the sale price of the camera.

Answer: £ _____ [2]

- 2.(a) Use your calculator to evaluate $\sqrt{13.5^2 - 4.9}$, writing down all the figures shown on your calculator display.

Answer: _____ [1]

- (b) Give your answer to part (a) corrected to 2 decimal places.

Answer: _____ [1]

3. Solve the following simultaneous equations:

$$2x - 3y = 21$$

$$x + 4y = -6$$

Answer: $x =$ _____

$y =$ _____ [4]

4. The minute hand of a clock is 10 cm long. Calculate how far the tip of this hand travels in one week, giving your answer corrected to the nearest cm.

Answer: _____ cm [3]

5. Simplify the following expressions:

(a) $3x + y - 6x + 2y$

Answer: _____ [2]

(b) $2(3x - 2) - 4x(2 - x)$

Answer: _____ [3]

(c) $\frac{12a^3b}{3a^2b^2}$

Answer: _____ [3]

(d) $(2x + 1)(x - 2)$

Answer: _____ [3]

6. Solve the following equations:

(a) $\frac{12}{y} = 60$

Answer: $y =$ _____ [2]

(b) $2(6 - x) + 4(x + 2) = 34$

Answer: $x =$ _____ [3]

7.

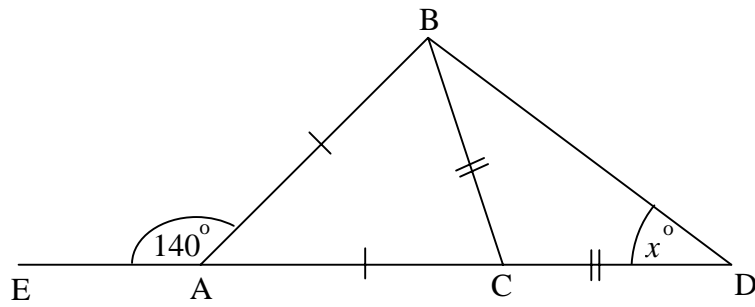

In the diagram above, $AB = AC$ and $BC = CD$ and angle $EAB = 140^\circ$.

Find the value of x .

Answer: $x =$ _____ [3]

8. You are given that: $44100 = 2 \times 2 \times 3 \times 3 \times 5 \times 5 \times 7 \times 7$

Using the above result, **show** how you would work out $\sqrt{44100}$ **without using a calculator**.

(To gain full marks, you must show all your working and not just write down the final answer).

Working:

Final Answer: _____ [3]

9. In each part of this question, five answers are given of which only one of them is correct. For each part work out which is the correct answer.

(i) The volume of a cube is 216 cm^3 . The length of a side of the cube (in cm) is:

- (A) 14.7 (B) 72 (C) 108 (D) 6 (E) none of these

Answer: _____ [1]

(ii) The cost of an article is first increased by 10%. Later, the cost is then again increased by a further 10%. The overall % increase in the cost of the article is:

- (A) 20 (B) 100 (C) 21 (D) 2 (E) none of these

Answer: _____ [1]

(iii) The letters PQRR can be written down in a number of different ways e.g. PQRR, QRPR. The total number of different ways of ordering the letters PQRR (using all four letters) is:

- (A) 4 (B) 24 (C) 6 (D) 3 (E) none of these

Answer: _____ [1]

(iv) $\frac{\sqrt{9} \times \sqrt[3]{27}}{3^2}$ is equal to:

- (A) 9 (B) $\frac{1}{3}$ (C) 3 (D) 1 (E) none of these

Answer: _____ [1]

10. 1430 cm^3 of a drink can be made up in two ways:

Method (i) 8 parts orange juice mixed with 3 parts water

or

Method (ii) 9 parts orange juice mixed with 4 parts water.

(a) Calculate the amount of orange juice used in each method of making up the drink.

Answer: Method (i) _____ cm^3

Method (ii) _____ cm^3 [4]

(b) Which method makes a drink which is the stronger in taste?

Answer: _____ [1]

11. My watch says 9.30. Work out the obtuse angle between the minute hand and the hour hand.

Answer: _____ $^\circ$ [3]

12.

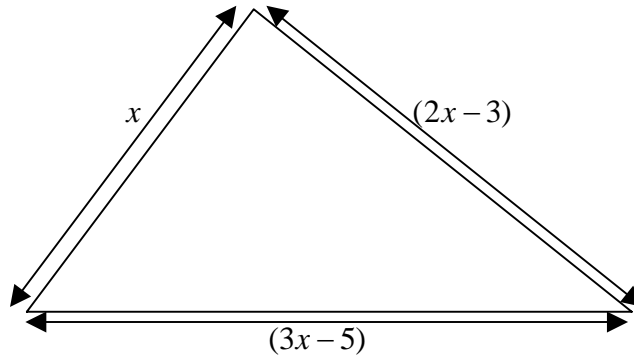

The diagram above (which is not drawn to scale) shows a triangle with sides x , $(2x-3)$ and $(3x-5)$. Find the three values of x for which the triangle is **isosceles**.

Answer: $x =$ _____, $x =$ _____, $x =$ _____ [5]

13.(a) The mean weight of 6 ballet dancers is 55 kg. The mean weight of 10 rugby players is 100 kg.

Calculate the mean weight of all 16 people.

Answer: _____ kg [4]

(b) A, B and C represent three numbers. The mean of A, B and C is A. Calculate the mean of B and C.

Answer: _____ [4]

14.

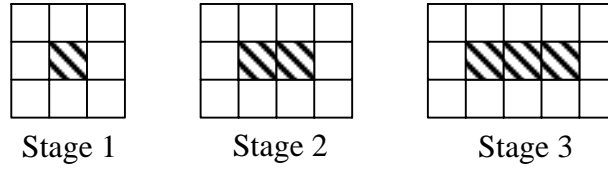

The diagram above shows a garden patio which is developed in stages using black and shaded square tiles.

(a) Complete the table below showing the number of **white** tiles in each stage.

Stage	Number of white tiles
1	
2	10
3	
4	

[3]

(b) Write down the number of white tiles in the 20th stage.

Answer: _____ [2]

(c) Write down a formula for the number of white tiles in the n^{th} stage in terms of n .

Answer: _____ [2]

(d) Calculate which stage would give a patio containing 76 white tiles.

Answer: _____ [3]

15. In this question, give your answers corrected to 2 decimal places. (The diagrams are not drawn to scale).

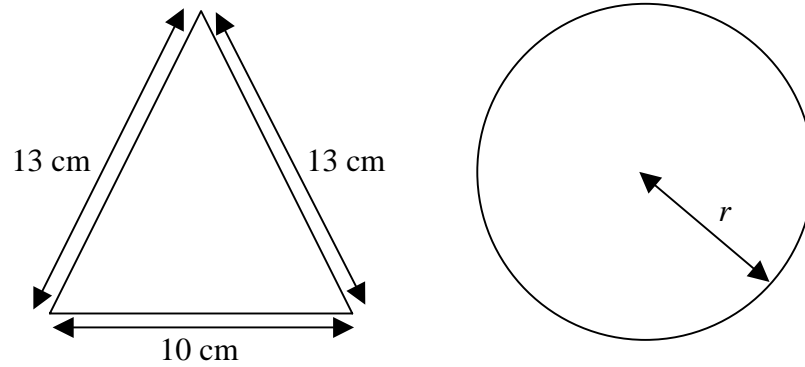

- (a) If the perimeter of the triangle is the same as the circumference of the circle, calculate the value of r , the radius of the circle.

Answer: $r =$ _____ cm [3]

- (b) If instead the triangle on the left has the same area as the circle on the right, calculate the new value of r , the radius of this new circle.

Answer: $r =$ _____ cm [5]

16.(a) Complete the table of values for $y = 2 - x^2$.

x	-3	-2	-1	0	1	2	2.5	3
y			1				-4.25	

[3]

(b) Plot and label the graph of $y = 2 - x^2$ on the axes **on the next page**.

[4]

(c) Looking at the curve you have drawn on the next page, write down the equation of the axis of symmetry of the curve $y = 2 - x^2$.

Answer: _____ [1]

(d) Complete the table of values for $y = x - 1$.

x	-3	0	3
y		-1	

[2]

(e) On the same axes used in part (b), plot and label the graph of $y = x - 1$.

[1]

(f) Using your graphs, write down estimates of the solutions of the equation $3 - x - x^2 = 0$.

Answer: $x =$ _____

$x =$ _____ [2]

Graph paper for question 16

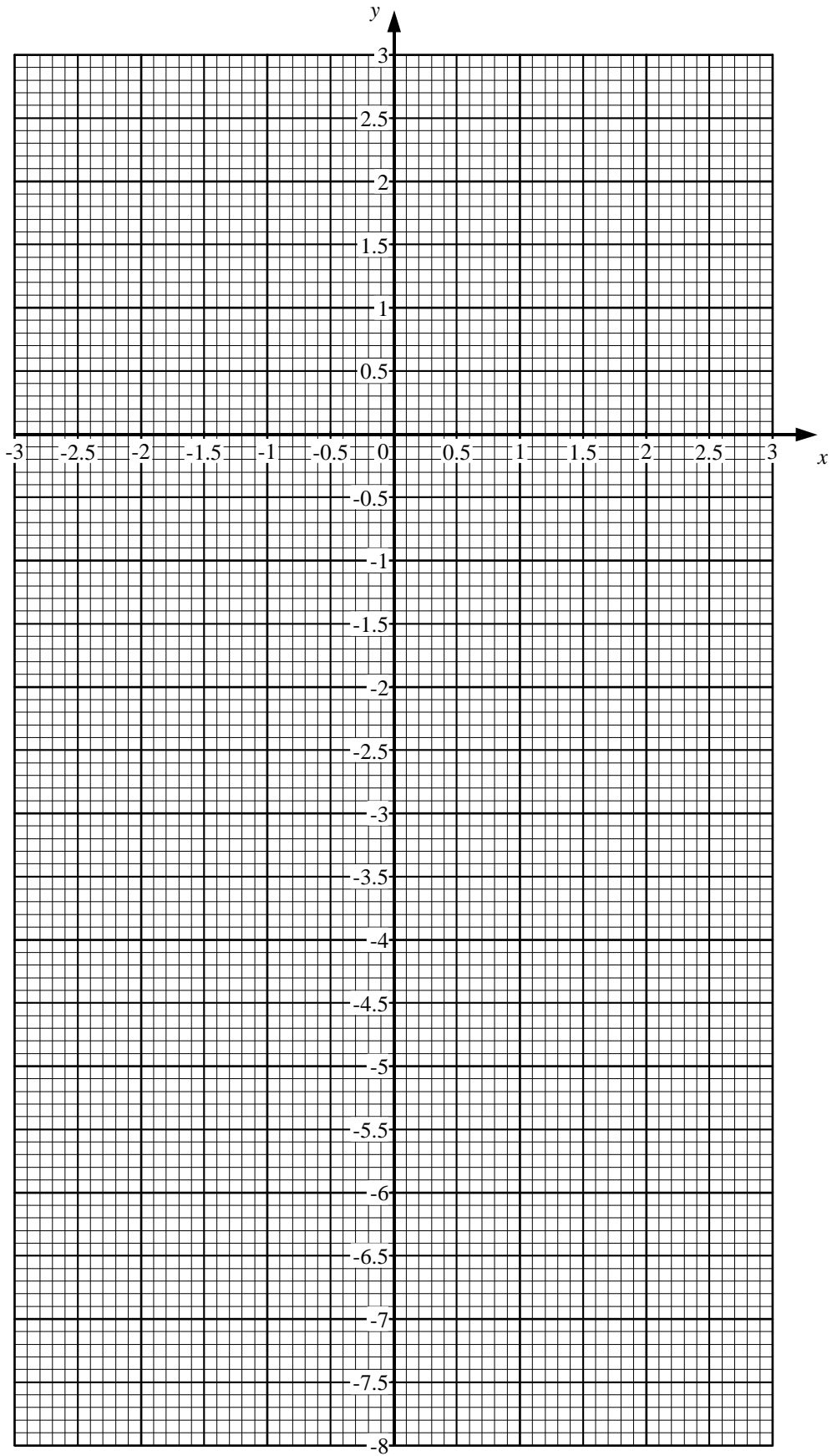

17. The diagrams below are not drawn to scale.

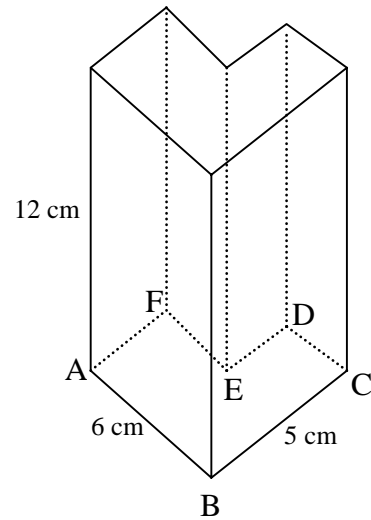
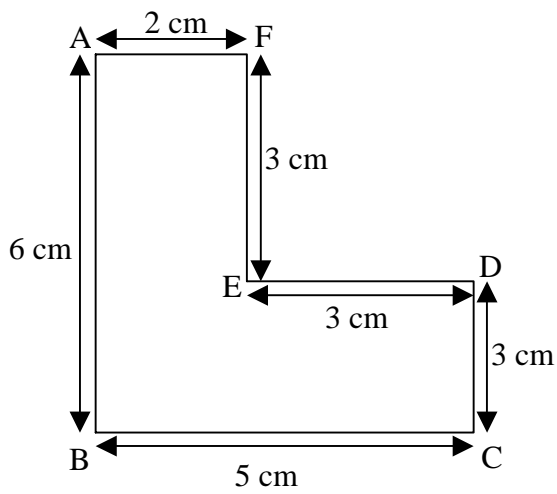

The diagram on the left shows the base of a prism (all angles are right angles). The diagram on the right shows the prism (whose height is 12 cm) standing on its base.

Calculate:

- (a) the volume of the prism;

Answer: _____ cm^3 [3]

- (b) the total surface area of the prism;

Answer: _____ cm^2 [3]

18. The grid below shows the mileage counter of Ben's car. The car is used every day to travel a variety of distances.

0	4	1	6	7	6
---	---	---	---	---	---

Calculate the probability that in exactly one year's time the mileage again ends in 76.

Answer: _____ [3]

19. Wally is 101.214 years old. Calculate his age this time tomorrow, giving your answer to 4 decimal places.

Answer: _____ years [2]

END OF EXAMINATION

**IF YOU HAVE TIME, GO BACK AND CHECK YOUR
WORKING**